

*Istruzioni di montaggio*

*Assembling instructions*

*Montageanleitung*

*Instructions de montage*

*Instrucciones para el montaje*

Porta scorrevole per nicchia

Sliding door for niche

Schiebetür für Nische

Porte coulissante pour niche

Puerta correderas entre

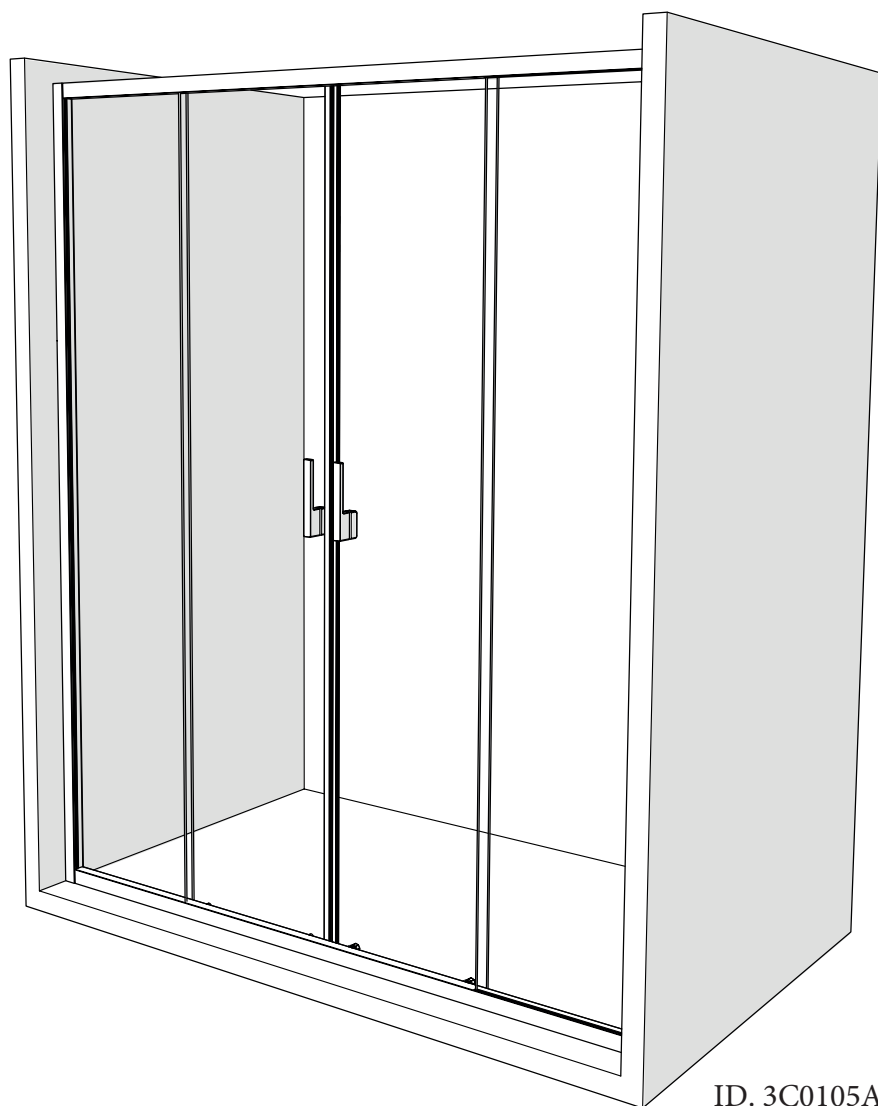

ID. 3C0105A01

**Importante!**

Prima del montaggio controllare se il prodotto ha subito danni di trasporto. Per danni su prodotti già installati non si assume alcuna responsabilità.

Per la pulizia utilizzare esclusivamente il detergente consigliato, oppure un detergente a PH neutro. Non utilizzare solventi, detergenti abrasivi, acidi alcalini, ossidanti o contententi cloro.

**Utensili per il montaggio:**

Livella, matita, bulino, martello, trapano, punta da muro 6 mm per acciaio 3 mm, cacciavite a croce, cacciavite piatto, silicone.

**Attenzione:**

Controllare le condizioni nelle quali si trovano sia la parete che le linee di gas, corrente ed acqua.

I tasselli e le viti fornite a corredo alla cabina doccia sono adatti per materiale edile in cemento armato e di costruzione. Per pareti in materiale costruttivo diverso utilizzare elementi di fissaggio specifici per quel tipo di materiale.

Utilizzare solo silicone o materiale isolante adatto alle superfici sulle quali verrà montata la cabina doccia. Il fissaggio a parete, il montaggio e la siliconatura della cabina doccia devono essere eseguiti in modo preciso e professionale. In caso di dubbi e domande in riferimento al montaggio della cabina doccia contatti il servizio clienti.

**Siliconatura:**

A montaggio ultimato pulire la cabina doccia e le piastrelle. Siliconare lungo i profili di compensazione e lungo il cristallo. Non utilizzare la cabina doccia per le 24 ore successive, in modo da garantire l'asciugatura del silicone.

**Important!**

Before assembling the shower, please control if the product has been damaged by the transport. We don't assume responsibility for damaged products which are already assembled.

For cleaning use a pH-neutral cleaning agent or the special cleaner recommended by us. Not to use are solvents, as well as alkaline, solvent, acid and chloric or scrubbing agents.

**Required assembly tools:**

Water level, pencil, hammer, drill, drill 6 mm, cross-shaped screwdriver, screwdriver, steeldrill 3mm, silicon.

**Attention:**

Please ensure to check the wall condition and the position of electrical wiring, gas and water piping.

Plugs and screws, provided with the shower enclosure, are only suitable for masonry walls. For different wall construction and material types, please use the appropriate fixing means.

Use only sealants suitable for the surfaces and materials on which the shower enclosure will be installed. Erection, installation, fixing on the wall and sealing of the shower enclosure must be properly done according to good practice. In case of doubt on erection and installation procedures, please contact the reseller.

**Apply silicon:**

At least please clean the shower enclosure and the tiles and proof the compensation profiles and the glass from outside with silicone. Before using the shower enclosure let pass minimum 24 hours.

**Wichtig!**

Bitte überprüfen Sie Ihre Duschkabine vor der Montage auf Transportschäden. Für Schäden an bereits montierten Produkten kann keine Haftung übernommen werden.

Zur Reinigung benutzen Sie ein PH neutrales Reinigungsmittel oder den von uns empfohlenen Spezialreiniger. Verwenden Sie keine scheuernden, alkalischen, säure oder chlorhaltigen Reinigungsmittel sowie Oxidations- und Lösungsmittel.

**Werkzeuge für die Montage:**

Wasserwaage, Bleistift, Körner, Hammer, Bohrmaschine, Steinbohrer 6mm, Kreuzschraubenzieher, Schraubenzieher, Stahlbohrer 3mm, Silikon.

**Achtung:**

Kontrollieren Sie die Beschaffenheit der Wand, Licht, Gas und Wasserleitungen.

Die mit der Kabine mitgelieferten Dübel und Schrauben sind nur für sämtliche Beton und Mauerwerkbaustoffe geeignet. Für Wände anderer Bauart müssen Sie dafür geeignetes Befestigungsmaterial verwenden.

Verwenden Sie nur Silikon oder Dichtungsmasse, welche für die Oberflächen und Materialien geeignet sind, an denen die Duschkabine montiert wird. Die Befestigung an der Wand, die Montage und die Silikonierung der Duschkabine müssen sorgfältig und professionell durchgeführt werden. Falls Fragen bezüglich der Montage entstehen sollten, wenden Sie sich bitte an Ihren Wiederverkäufer.

**Übernehmen Silizium:**

Anschließend Kabine und Fliesen reinigen und die Gläser von außen mit Silikon abdichten. Vor Benutzen der Dusche Silikon mindestens 24 Stunden aushärten lassen.

**Attention!**

Avant de commencer les opérations de montage, assurez-vous que votre cabine n'a subi aucun dommage durant le transport. Les réclamations pour cause de dommage ne peuvent être acceptées lorsque la cabine est déjà placée.

Pour nettoyer veuillez utiliser s'il vous plaît un produit de nettoyage avec PH neutre ou le produit spéciale recommandé par nous. N'utilisez pas des solvants, ainsi qu'alcalins, acides ou produits avec du chlore ou agressif.

**Outils requis:**

Tournevis cruciforme, niveau à bulle, crayon, perceuse, mèche de 6 mm pour pierre, mèche de 3 mm pour acier et silicium.

**Attention:**

Il est important de vérifier l'absence de canalisations d'eau, de gaz ou de câbles électriques dans le mur.

Les chevilles et vis fournies avec la cabine ne sont appropriées pour tous les matériaux de maçonnerie et bétons. Pour des murs réalisés avec d'autres matériaux veuillez utiliser pour cela du matériel de fixation approprié.

N'utilisez que du silicone ou un produit d'étanchéité qui est approprié aux surfaces et matériaux, auxquels la cabine douche sera installée.

La fixation au mur, l'assemblage et le siliconnage de la cabine de douche doivent être mis en œuvre soigneusement et professionnellement.

Si des questions devaient naître concernant l'assemblage, veuillez vous adresser à votre détaillant.

**Appliquer le silicium:**

Ensuite nettoyer la cabine et les carreaux et rejointoyer avec silicone la cabine du côté extérieure. Respecter pour le silicone un délai de durcissement de 24 heures.

**Importante!**

Antes del montaje controlar si el producto tiene daños de transporte. Para daños a productos ya montados no asumamos alguna responsabilidad. Limpiar cada semana con agua y jabón, no utilizar diluentes, detergentes rasqueantes, bencina.

Para la limpieza utilizar un detergente con un PH neutral o el detergente neutral recomendado de duka. No utilizar diluentes y/o substancias alcalinas, substancias que contienen solventes, ácidos, cloro o materias abrasivas.

**Herramientas por el montaje:**

Nivel, lápiz, puntero, martillo, tallador, punta de 6 mm, 3 mm por acero, destornillador a cruz, destornillador plano y silicón.

**Atención:**

Controlar por favor las condiciones de las paredes y la ubicación de líneas de gas, energía y agua.









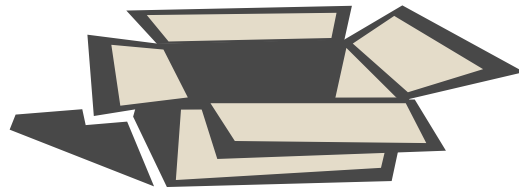

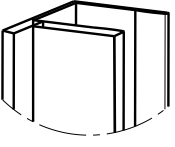
Los tacos y los tornillos enviados juntos a la mampara son adecuados para material edil en cemento y para material de construcción de paredes. Para paredes realizadas con material constructivo diferente tiene que utilizar material de fijación en función del material de construcción.

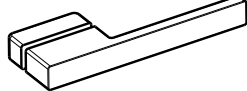
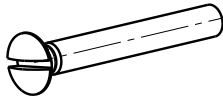
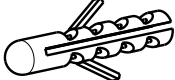
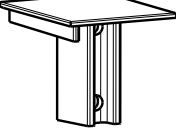
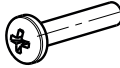
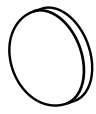
Utilizar solo silicón o material de insolación adaptado a las superficies sobre las que se fija la mampara. La fijación a pared, el montaje y la siliconatura de la mampara tienen que ser hechas en manera precisa y profesional. Si tiene preguntas al respecto del montaje, les rogamos de contactar el distribuidor.

**Aplique silicona:**

Después limpiar la cabina de ducha y los azulejos y siliconar los perfiles de compensación y el cristal desde afuera. Antes de utilizar la cabina de ducha esperar para mínimo 24 horas, así que se seca el silicón.



<p><b>1</b> N°2</p> 	<p><b>2</b> N°2</p> 	<p><b>3</b> N°4</p> 	<p><b>4</b> N°2</p> 
<p><b>5</b> N°6</p> <p>3.9x32</p> 	<p><b>6</b> N°6</p> 	<p><b>7</b> N°4</p> 	<p><b>8</b> N°6</p> <p>3.5x13</p> 
<p><b>9</b> N°6</p> 	<p><b>10</b> N°1</p> 	<p><b>11</b> N°2</p> 	<p><b>12</b> N°2</p> 
<p><b>13</b> N°4</p> 	<p><b>14</b> N°8</p> <p>3.5x32</p> 	<p><b>15</b> N°2</p> <p>Fisso Fix Fixiert Fixé Fija</p> 	<p><b>16</b> N°2</p> <p>Porta Door Port Porte Puerta</p> 

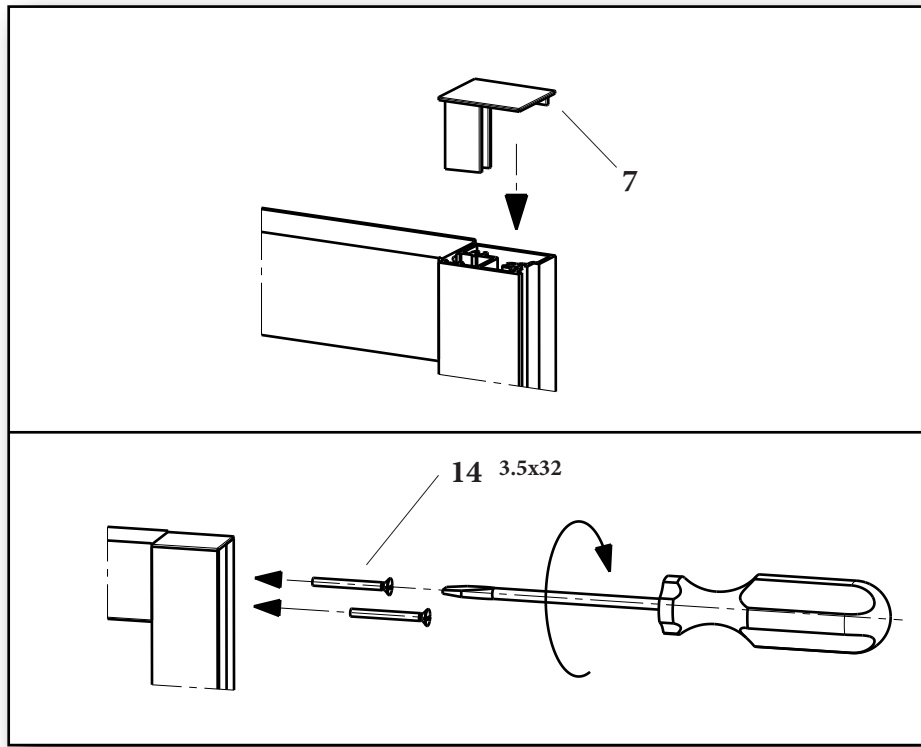
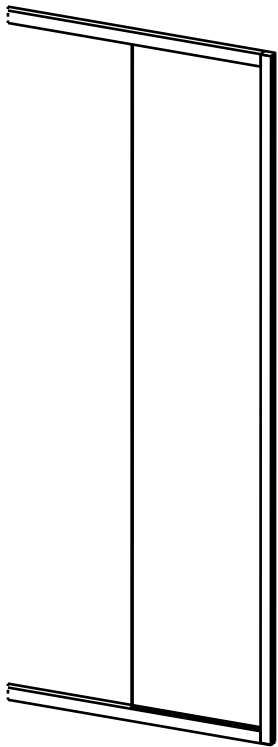
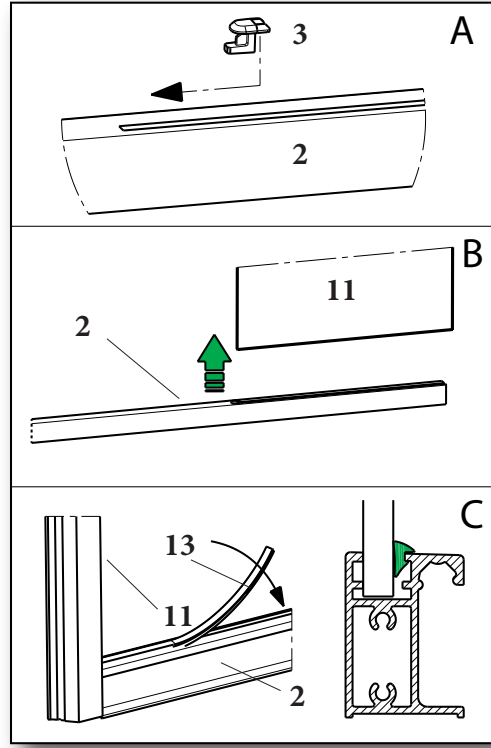
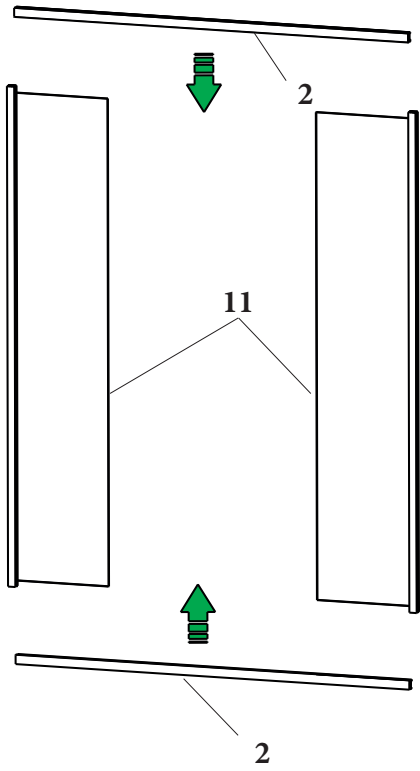

4

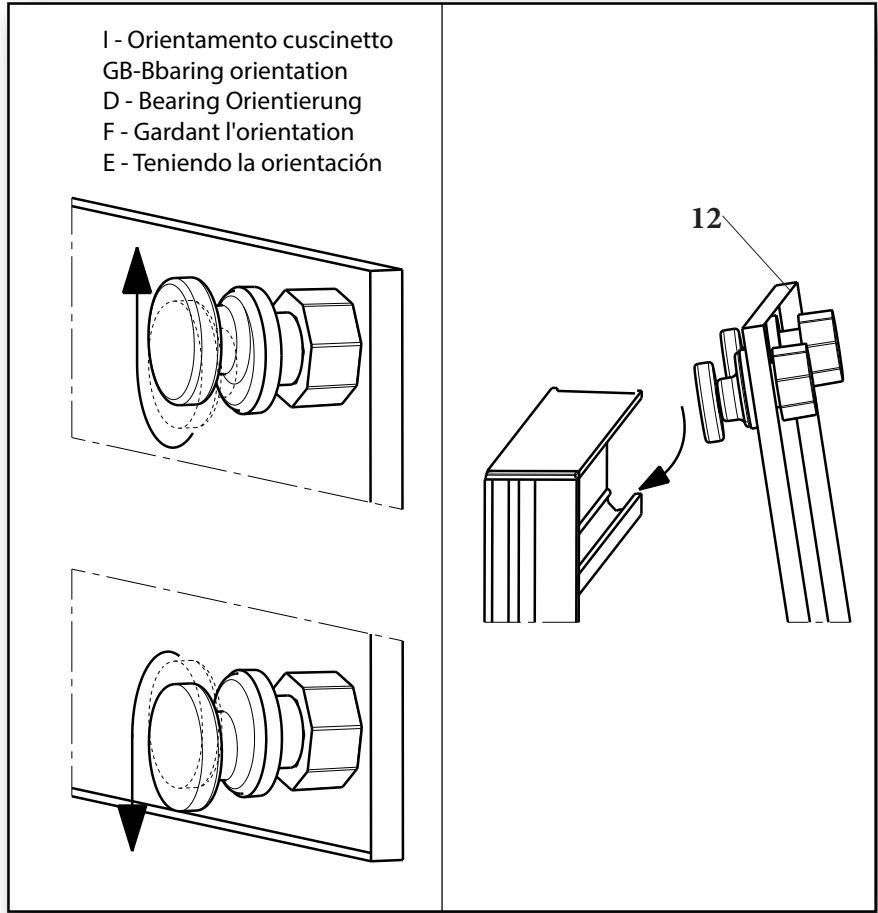
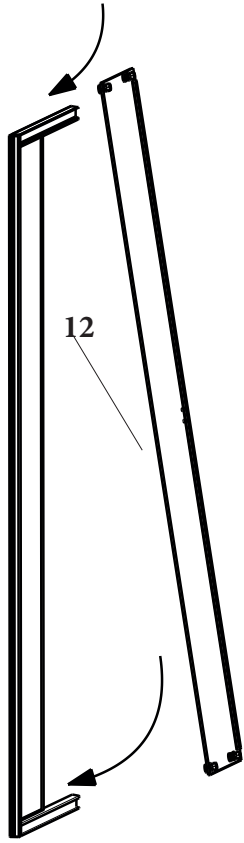

5

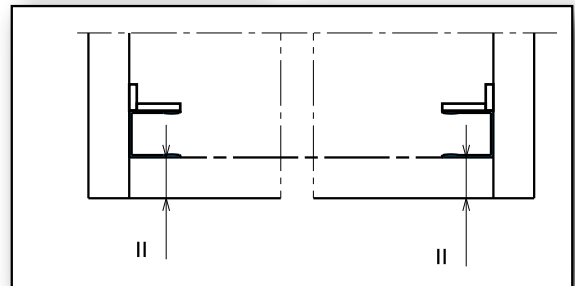
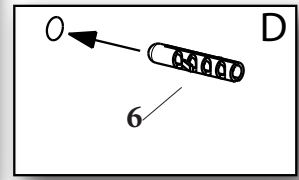
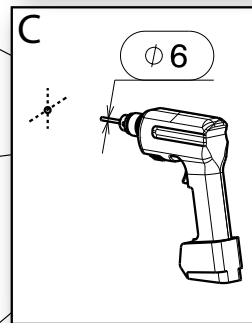
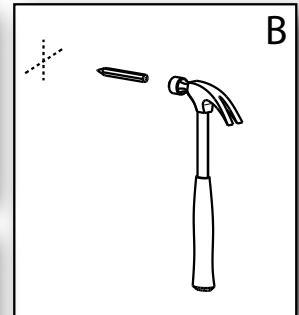
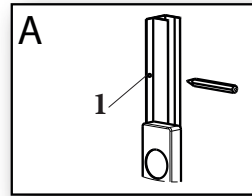
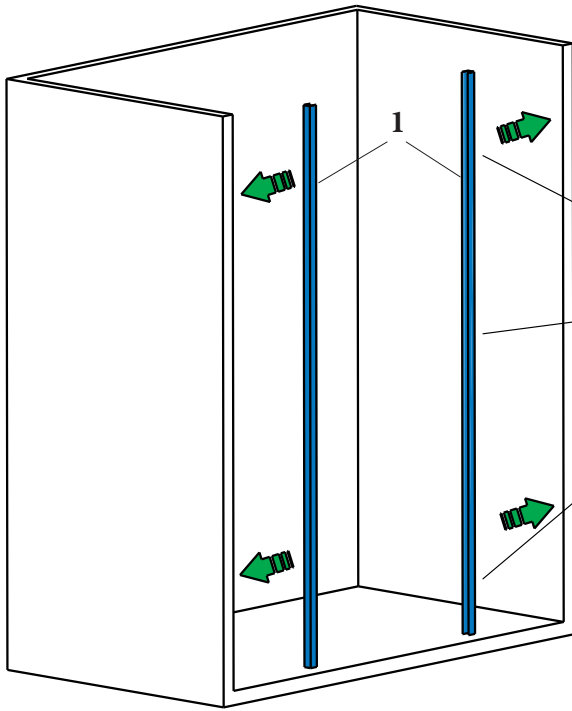

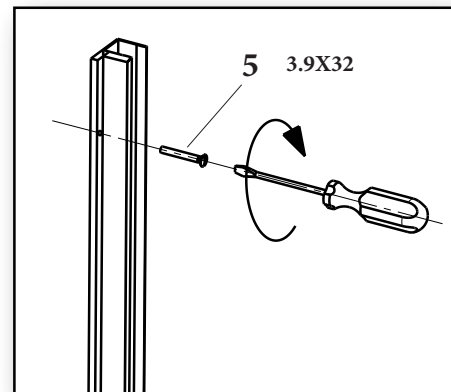
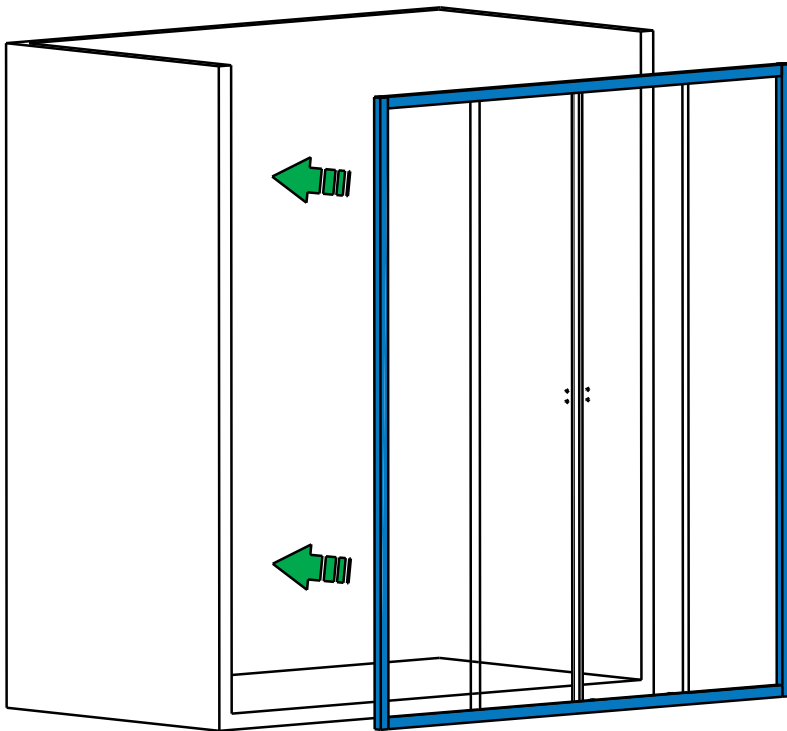
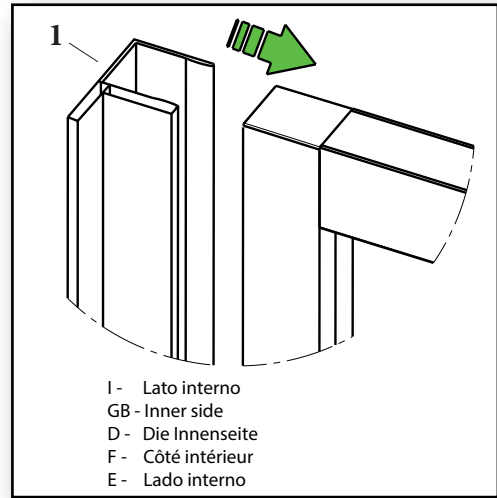
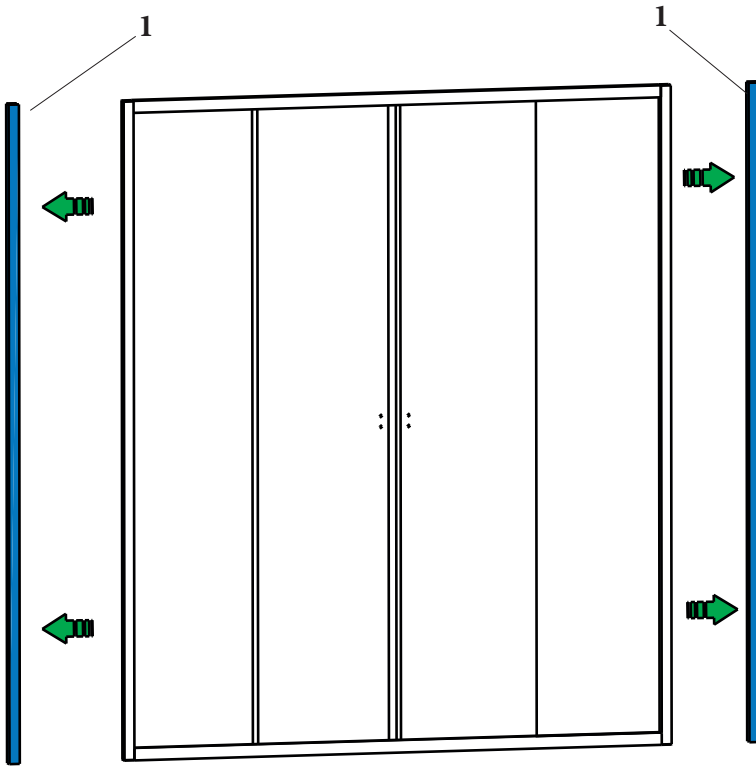

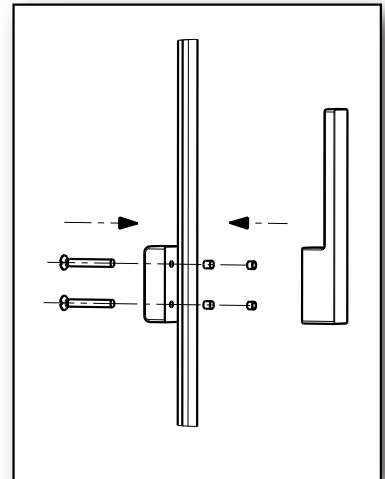
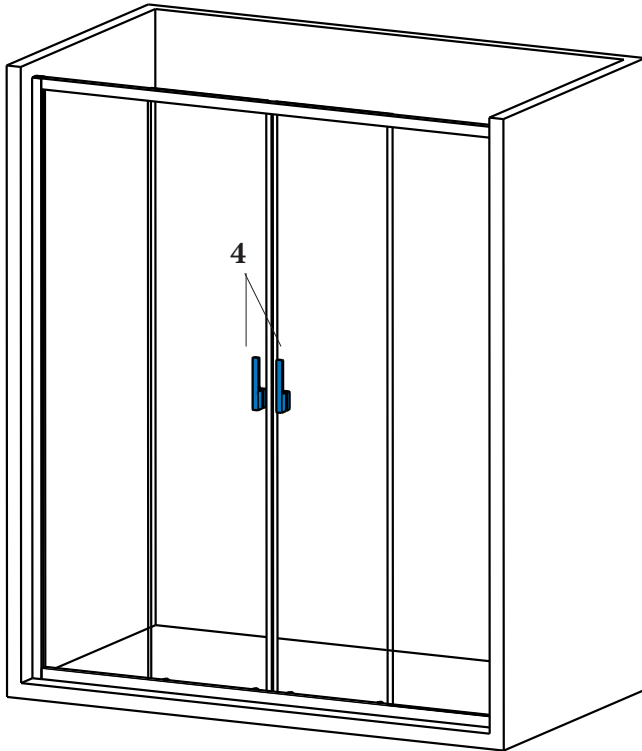
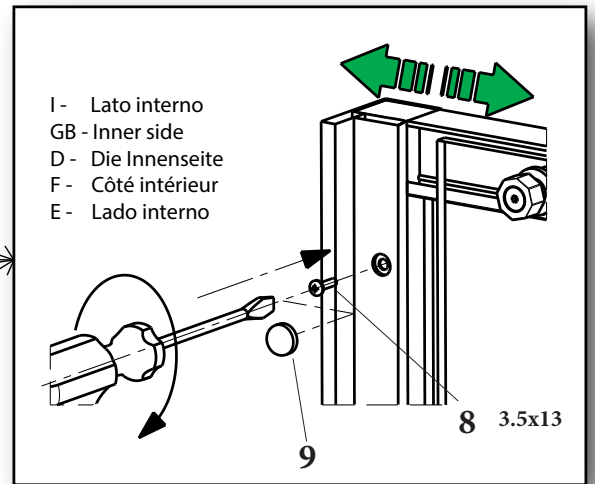
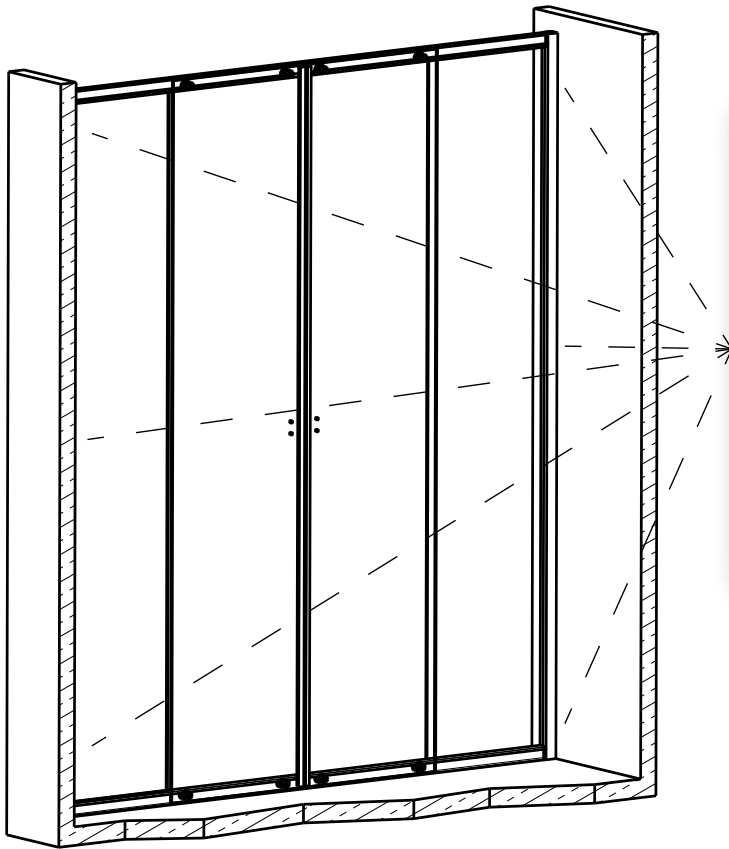



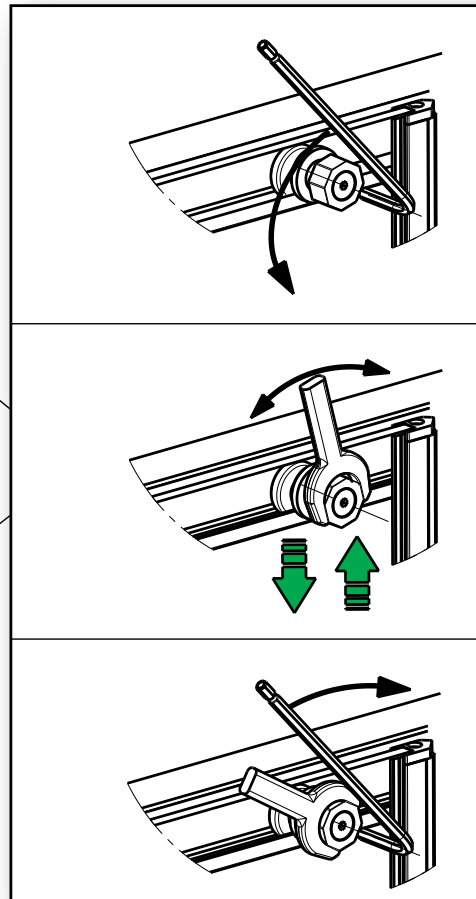
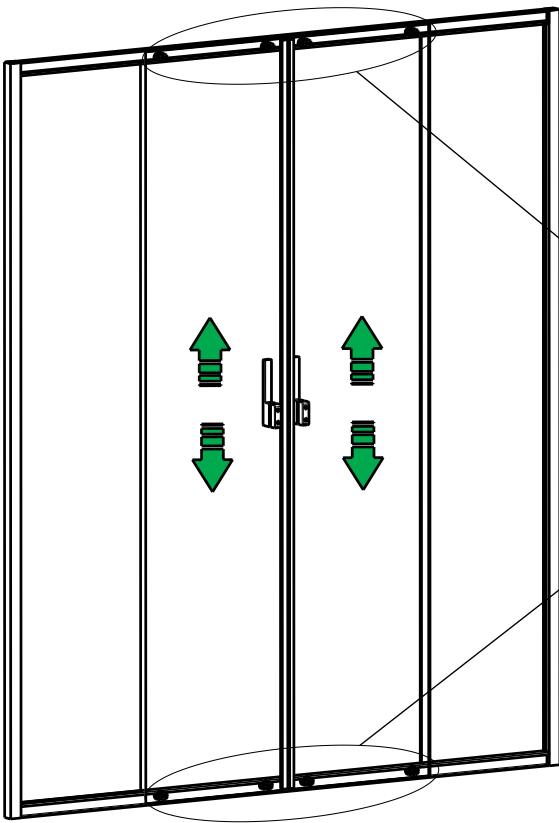
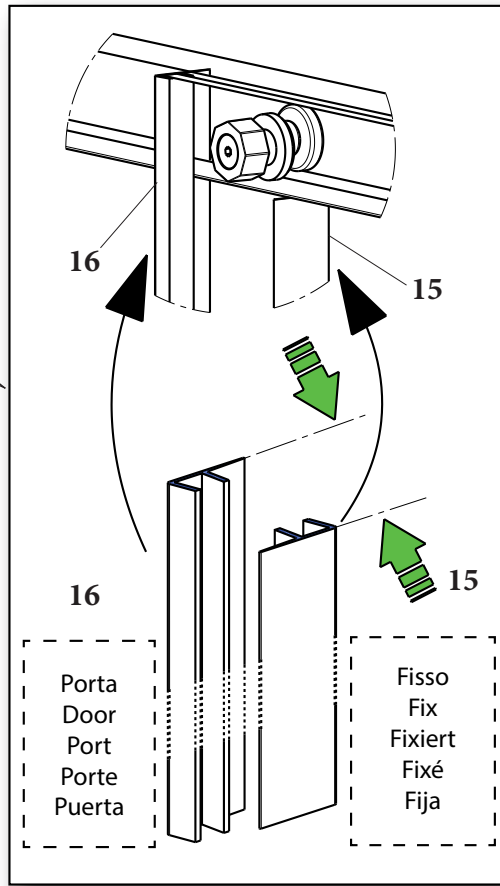
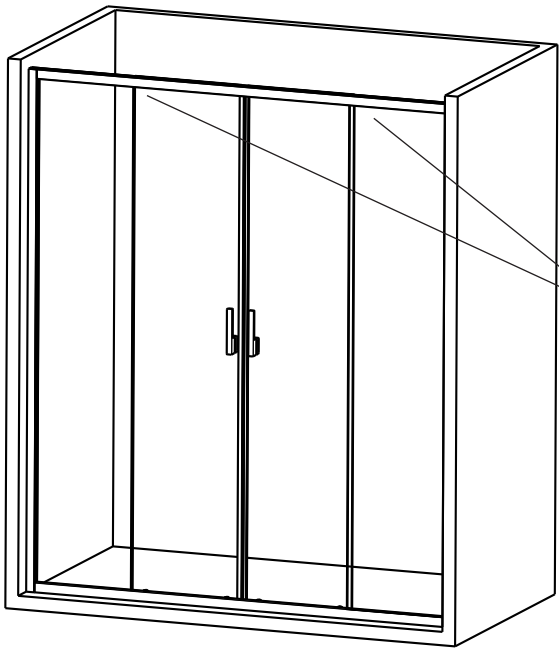

12

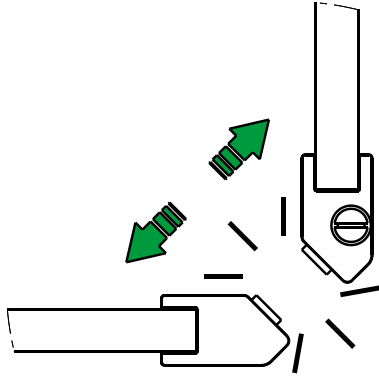

I - Se i magneti si respingono, invertirne uno.

GB - If the magnets repel each other, reversing one.

D - Wenn die Magnete sich gegenseitig abstoßen, Wende einer der Magneten.

F - Si les aimants se repoussent mutuellement, en inversant l'un des aimants.

E - Si los imanes se repelen entre sí, revirtiendo uno de los imanes.

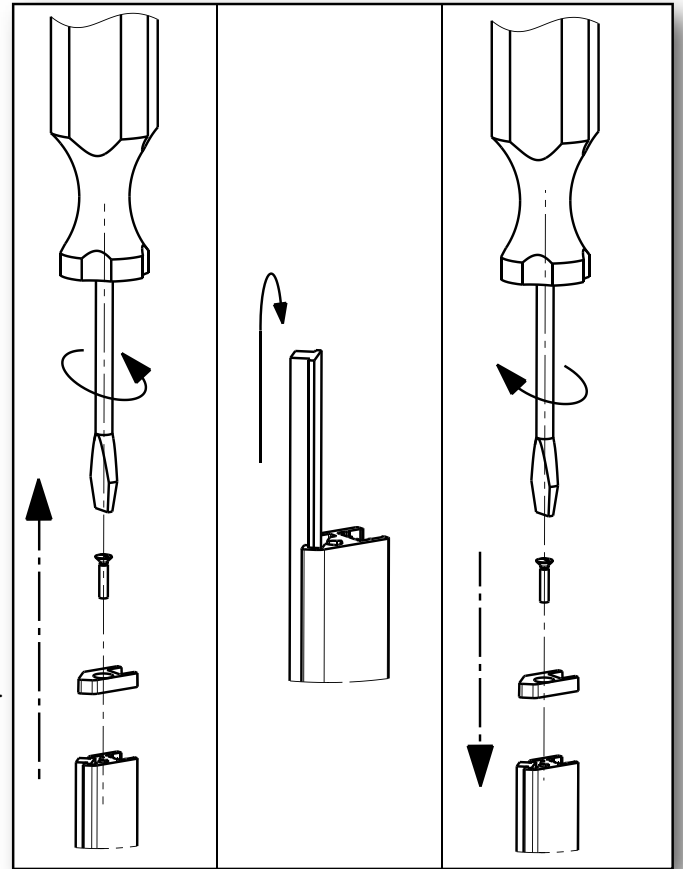

13

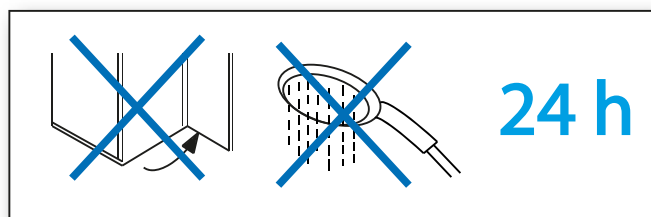
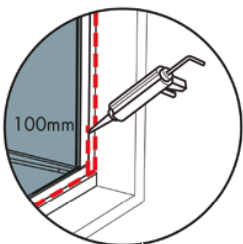
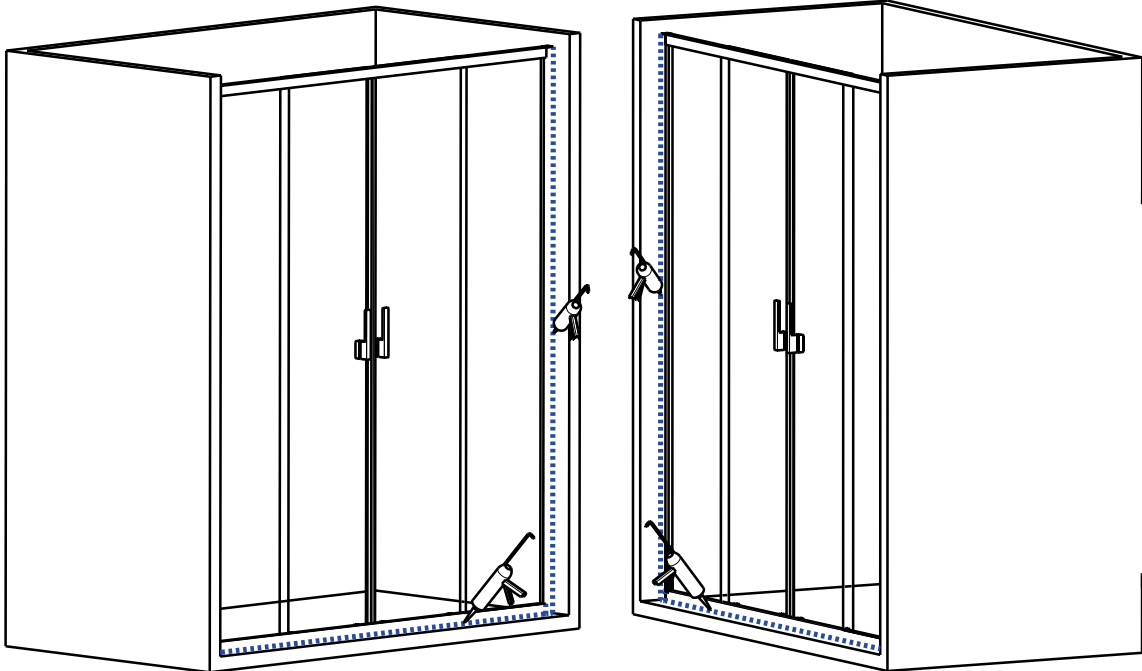

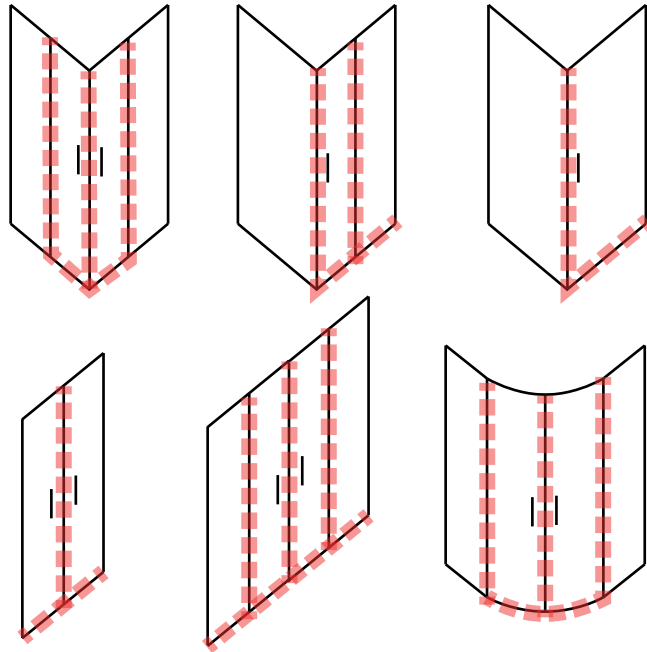
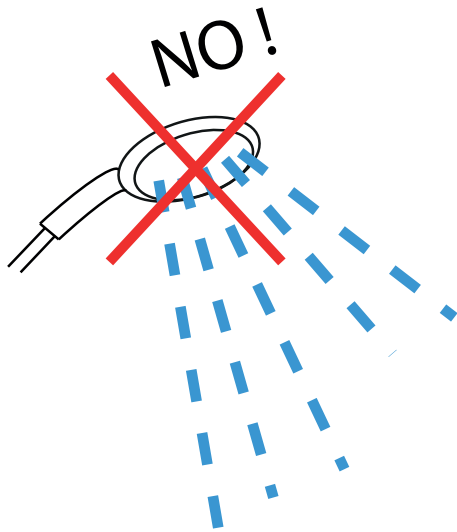
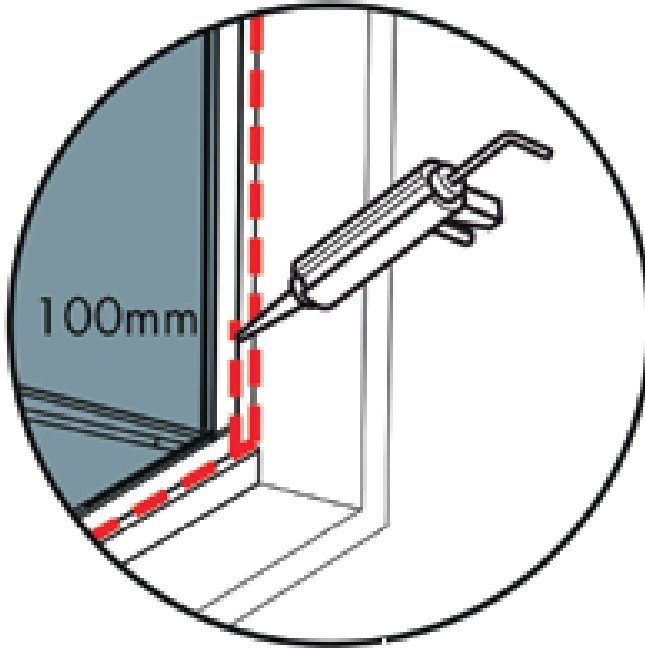
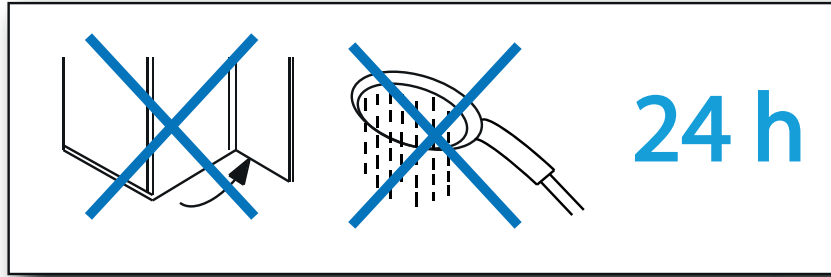

*Istruzioni di montaggio*

*Assembling instructions*

*Montageanleitung*

*Instructions de montage*

*Instrucciones para el montaje*

Parete fissa F2

Fixed wall F2

Feste Scheibe F2

Panneau fixe F2

Panel fijo F2

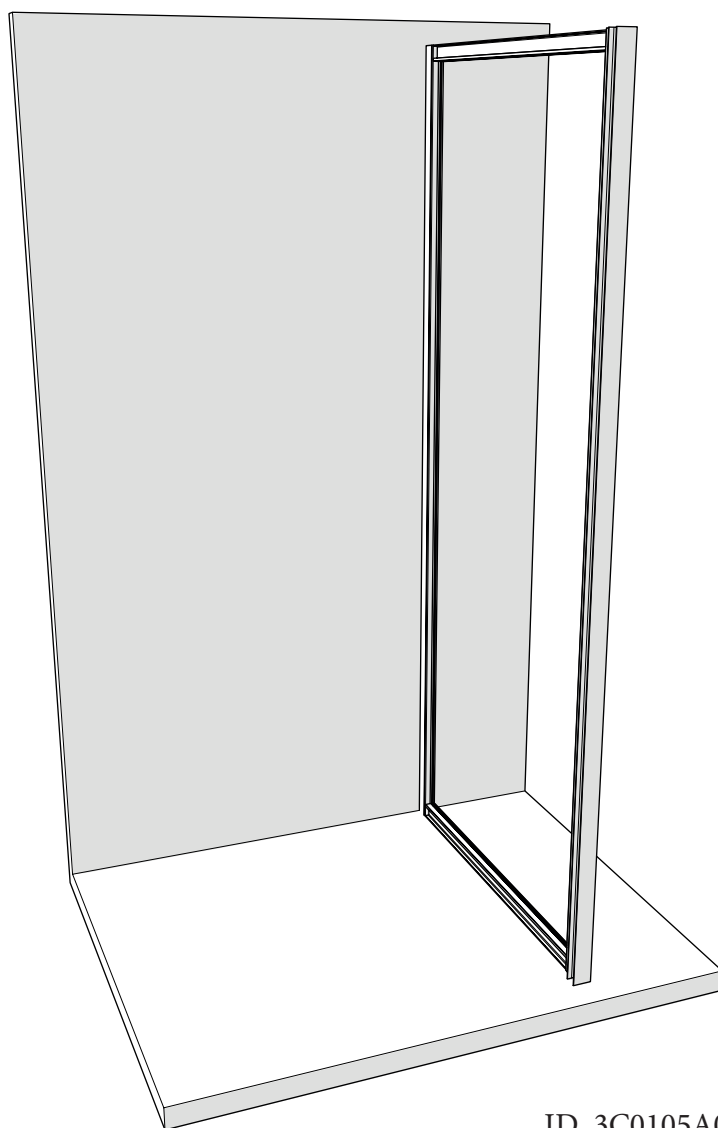

ID. 3C0105A05

**Importante!**

Prima del montaggio controllare se il prodotto ha subito danni di trasporto. Per danni su prodotti già installati non si assume alcuna responsabilità.

Per la pulizia utilizzare esclusivamente il detergente consigliato, oppure un detergente a PH neutro. Non utilizzare solventi, detergenti abrasivi, acidi alcalini, ossidanti o contententi cloro.

**Utensili per il montaggio:**

Livella, matita, bulino, martello, trapano, punta da muro 6 mm per acciaio 3 mm, cacciavite a croce, cacciavite piatto, silicone.

**Attenzione:**

Controllare le condizioni nelle quali si trovano sia la parete che le linee di gas, corrente ed acqua.

I tasselli e le viti fornite a corredo alla cabina doccia sono adatti per materiale edile in cemento armato e di costruzione. Per pareti in materiale costruttivo diverso utilizzare elementi di fissaggio specifici per quel tipo di materiale.

Utilizzare solo silicone o materiale isolante adatto alle superfici sulle quali verrà montata la cabina doccia. Il fissaggio a parete, il montaggio e la siliconatura della cabina doccia devono essere eseguiti in modo preciso e professionale. In caso di dubbi e domande in riferimento al montaggio della cabina doccia contatti il servizio clienti.

**Siliconatura:**

A montaggio ultimato pulire la cabina doccia e le piastrelle. Siliconare lungo i profili di compensazione e lungo il cristallo. Non utilizzare la cabina doccia per le 24 ore successive, in modo da garantire l'asciugatura del silicone.

**Important!**

Before assembling the shower, please check that the product has not been damaged during transportation. We will not assume responsibility for damaged products, which are already assembled.

When cleaning, only use the recommended detergent or a pH-neutral cleaning agent. Do not use solvents, abrasive detergents, alkaline, oxidising or chlorine-based acids.

**Required assembly tools:**

Water level, pencil, chisel, hammer, drill, 6 mm wall drill bit for 3 mm steel components, Phillips screwdriver, slot screwdriver, silicone sealant.

**Attention:**

Please ensure to check the environment in which the walls are found and equally, check the positioning of gas pipes, the electrical wiring, and water pipes. The plugs and screws supplied with the shower enclosure, are only suitable for masonry walls. For different wall constructions and material types, please use the appropriate fixing means.

Use only silicone sealants or moulding compounds suited to the surfaces and materials to which the shower enclosure will be installed.

Erection, installation, and sealing of the shower enclosure must be accurately executed, according to good practice. Should you have any doubts with regard the erection and installation procedures, please contact Customer Services.

**Silicone Sealing:**

Upon completing the installation, clean the shower enclosure and the tiles. Seal the load balancing profiles and glass by applying a line of sealant along these edges. Allow 24 hours before using the shower enclosure to enable the silicone sealant to dry.

**Wichtig!**

Bitte überprüfen Sie Ihre Duschkabine vor der Montage auf Transportschäden. Für Schäden an bereits montierten Produkten kann keine Haftung übernehmen

Zur Reinigung darf ausschließlich der von uns empfohlene Spezialreiniger oder ein pH-neutrales Reinigungsmittel genutzt werden. Verwenden Sie keine Lösungsmittel, scheuernden, basischen, sauren, oxidierenden oder chlorhaltigen Reinigungsmittel.

**Werkzeuge für die Montage:**

Wasserwaage, Bleistift, Körner, Hammer, Bohrmaschine, 6mm-Steinbohrer, Kreuzschraubenzieher, Flachsraubenzieher, 3mm-Stahlbohrer, Silikon.

**Achtung:**

Kontrollieren Sie die Beschaffenheit der Wand auf Strom-, Gas- und Wasserleitungen.

Die mit der Kabine mitgelieferten Dübel und Schrauben sind nur für sämtliche Baumaterialien aus Stahlbeton und Mauerwerk geeignet. Für Wände anderer Bauart müssen Sie dafür geeignetes Befestigungsmaterial verwenden.

Verwenden Sie nur Silikon oder Dichtungsmassen, welche für die Oberflächen und Materialien geeignet sind, an denen die Duschkabine montiert wird. Die Befestigung an der Wand, die Montage und das Abdichten der Duschkabine mit Silikon müssen sorgfältig und professionell durchgeführt werden. Falls Fragen bezüglich der Montage entstehen sollten, wenden Sie sich bitte an den Kundendienst.

**Abdichten mit Silikon:**

Anschließend Kabine und Fliesen reinigen, und die Begrenzungsprofile und die Scheiben rundherum mit Silikon abdichten. Vor dem Benutzen der Dusche das Silikon mindestens 24 Stunden aushärten lassen.

**Important!**

Avant de commencer les opérations de montage, contrôler que la cabine n'ait subi aucun dommage durant le transport. Ne pourra accepter aucune réclamation après l'installation de la cabine de douche.

Pour les opérations d'entretien, n'utiliser que le produit conseillé ou un produit nettoyant à pH neutre. N'utiliser ni produits abrasifs ni oxydants, ni à base de solvant ou d'acide alcalin.

**Outils nécessaires:**

Niveau à bulle, crayon, burin, marteau, perceuse, forêt de 6 mm pour mur, forêt de 3 mm pour acier, tournevis cruciforme, tournevis à tête plate et silicone.

**Attention:**

Contrôler l'état du mur et l'absence de canalisations d'eau, de gaz ou de câbles électriques.

Les chevilles et les vis fournies en dotation sont adaptées pour béton et maçonnerie pleine. Pour des murs réalisés avec d'autres matériaux de construction, utiliser des éléments de fixation appropriés.

N'utiliser que de la silicone ou du matériel d'étanchéité approprié aux surfaces d'installation de la cabine. Les opérations de fixation au mur, d'assemblage et d'application de silicone doivent être effectuées de manière soignée et professionnelle. En cas de doute sur le montage de la cabine de douche, contacter notre service clientèle.

**Application de silicone:**

Une fois le montage terminé, nettoyer les carreaux et la cabine de douche. Appliquer la silicone le long des profils de compensation et des parois vitrées. Laisser sécher la silicone pendant 24 heures avant d'utiliser la cabine.

**Importante:**

Antes del montaje, compruebe si el producto ha sufrido daños durante el transporte. No asume ninguna responsabilidad por daños en productos ya instalados.

Para la limpieza utilice únicamente el detergente recomendado, o bien un detergente con pH neutro. No emplee disolventes, detergentes abrasivos, ácidos, alcalinos, oxidantes o que contengan cloro.

**Herramientas para el montaje:**

Nivel, lápiz, buril, martillo, taladro, broca para pared de 6 mm y para acero de 3 mm, destornillador de estrella, destornillador plano y silicona.

**Atención:**

Compruebe las condiciones en las que se encuentran la pared y las líneas de gas, corriente y agua.



Los tacos y tornillos incluidos con la cabina de ducha son aptos para material de construcción de cemento armado y de albañilería. Para paredes de material constructivo diferente, utilice elementos de fijación específicos para ese tipo de material.

Utilice solo silicona o material aislante apto para las superficies sobre las que se montará la cabina de ducha. La fijación a la pared, el montaje y el sellado con silicona de la cabina de ducha deben realizarse de manera precisa y profesional. En caso de dudas o preguntas sobre el montaje de la cabina de ducha, póngase en contacto con el servicio al cliente.

**Aplicación de la silicona:**

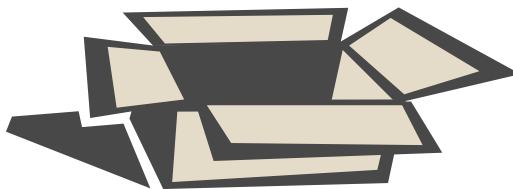
Una vez concluido el montaje, limpie la cabina de ducha y los azulejos. Aplique silicona a lo largo de los perfiles de compensación y a lo largo del cristal. No utilice la cabina de ducha durante las 24 horas siguientes, para dejar que se seque la silicona.

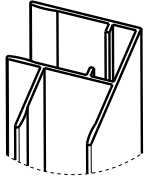
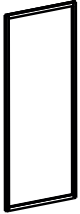
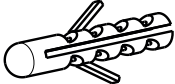
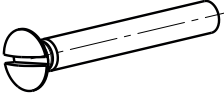

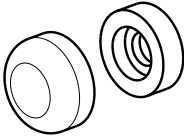
2 N°1 	3 N°1 	4 N°3 	5 N°3 3.9x32 
6 N°6 3.5x13 	7 N°6 		

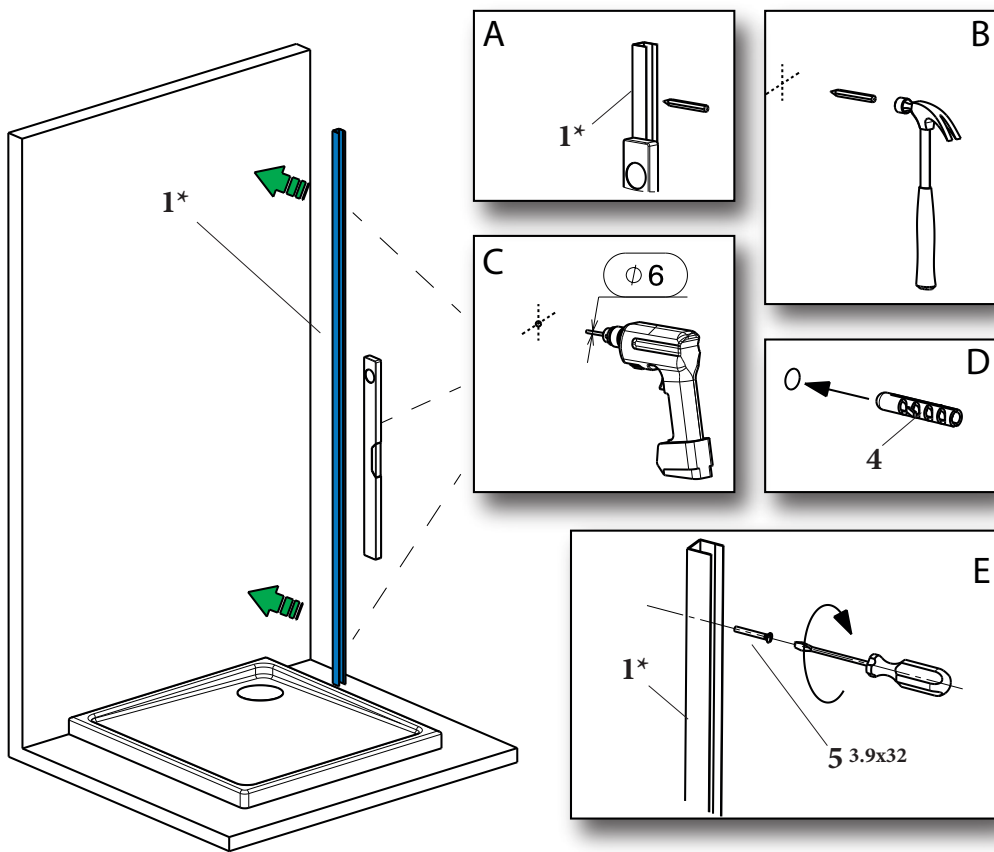

- \* Il componente "1" è contenuto nell'imballo della porta
- \* The component "1" is contained in packaging of the door
- \* Die Komponente "1" ist in der Verpackung der Tür enthalten
- \* La composante "1" est contenue dans l'emballage de la porte
- \* El componente de "1" figura en el empaque de la puerta

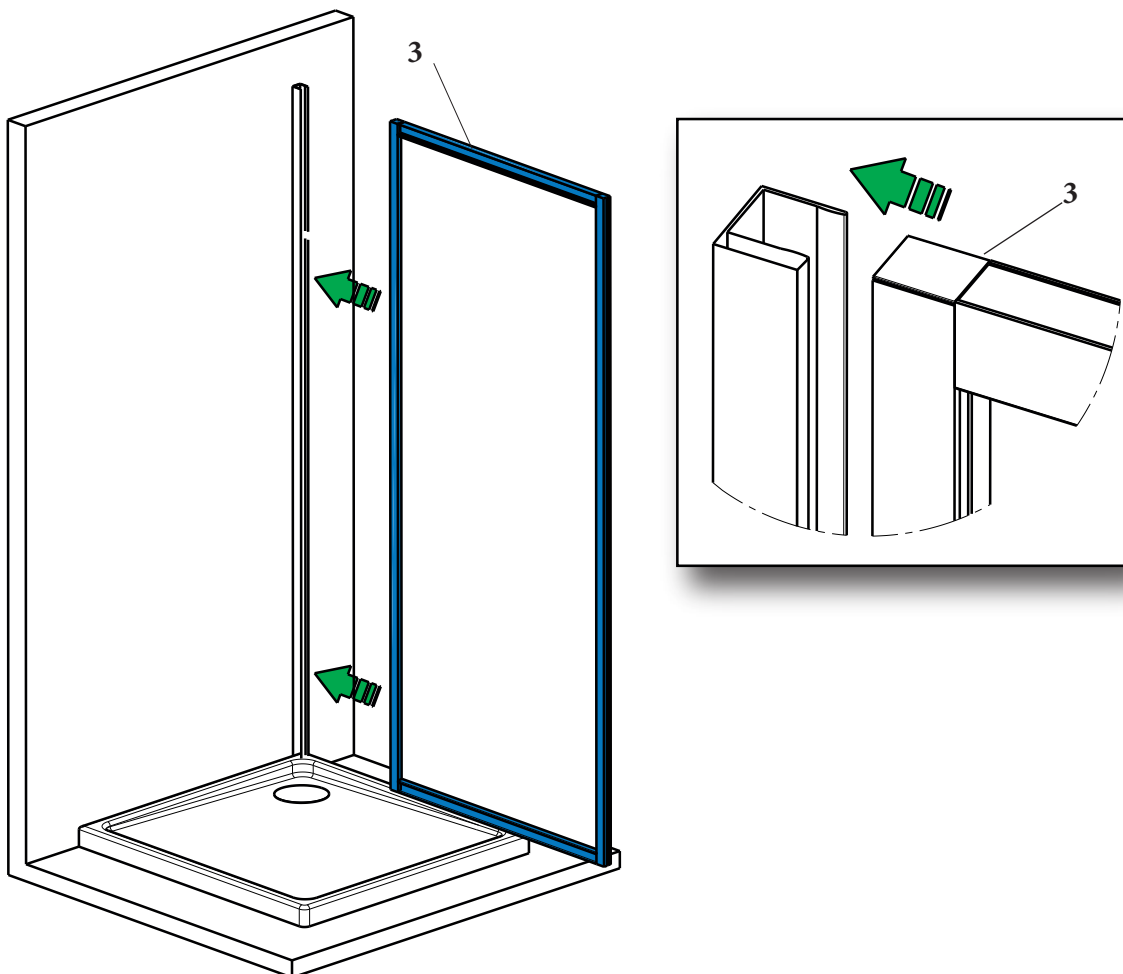



4

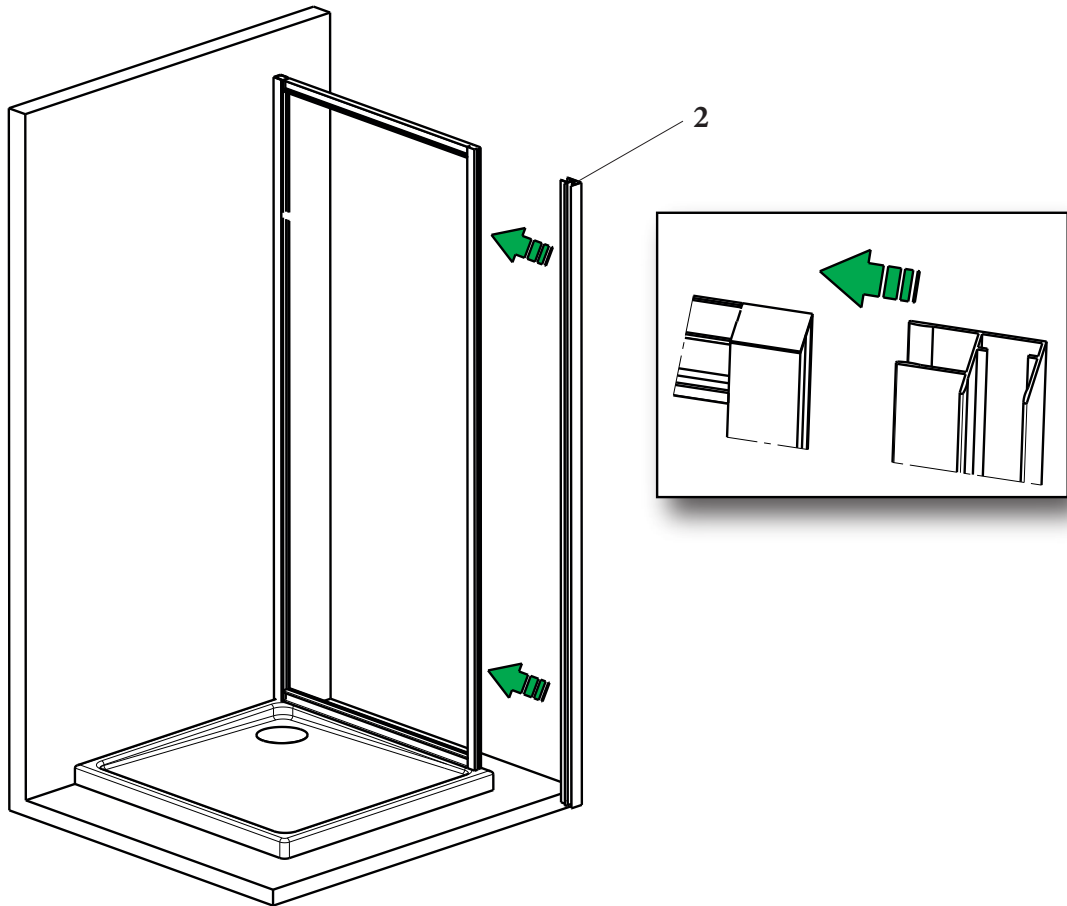

5

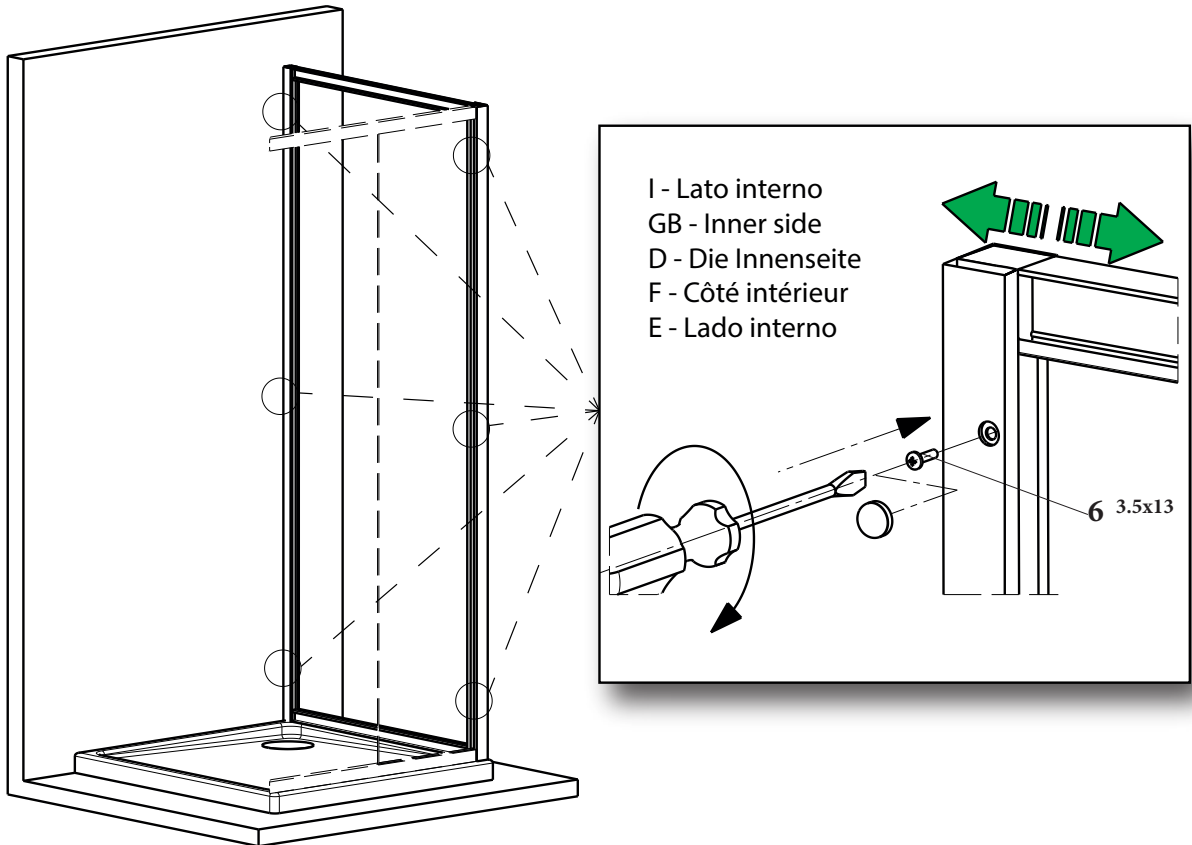

6

