

SC2 version

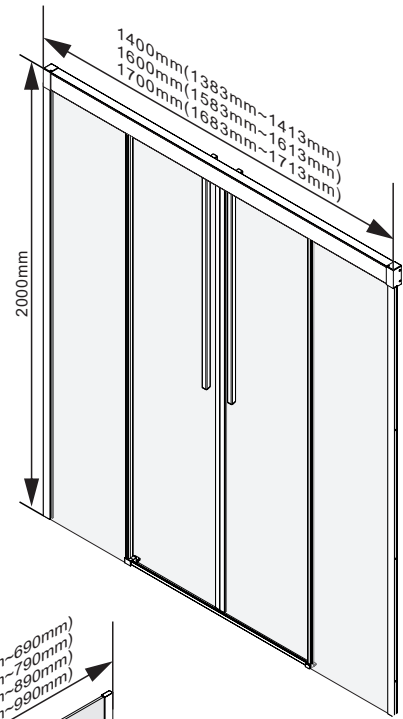

SC2+F version

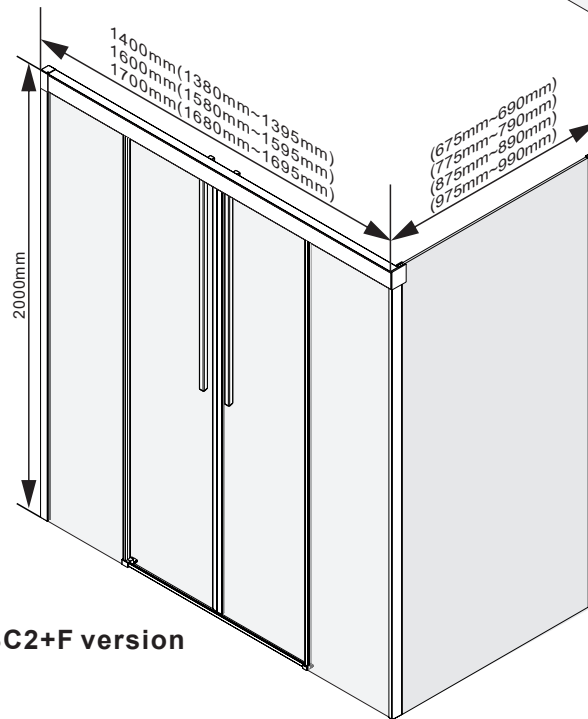

SC2+F+F version

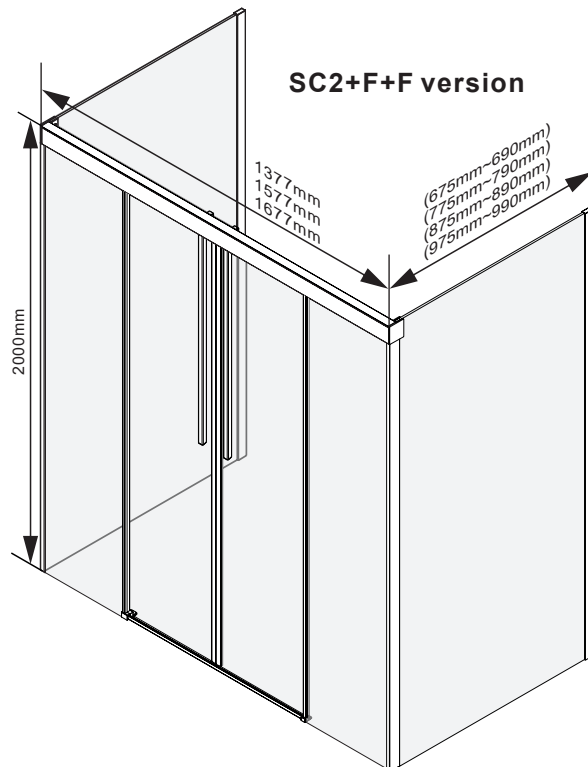

PARTS LIST

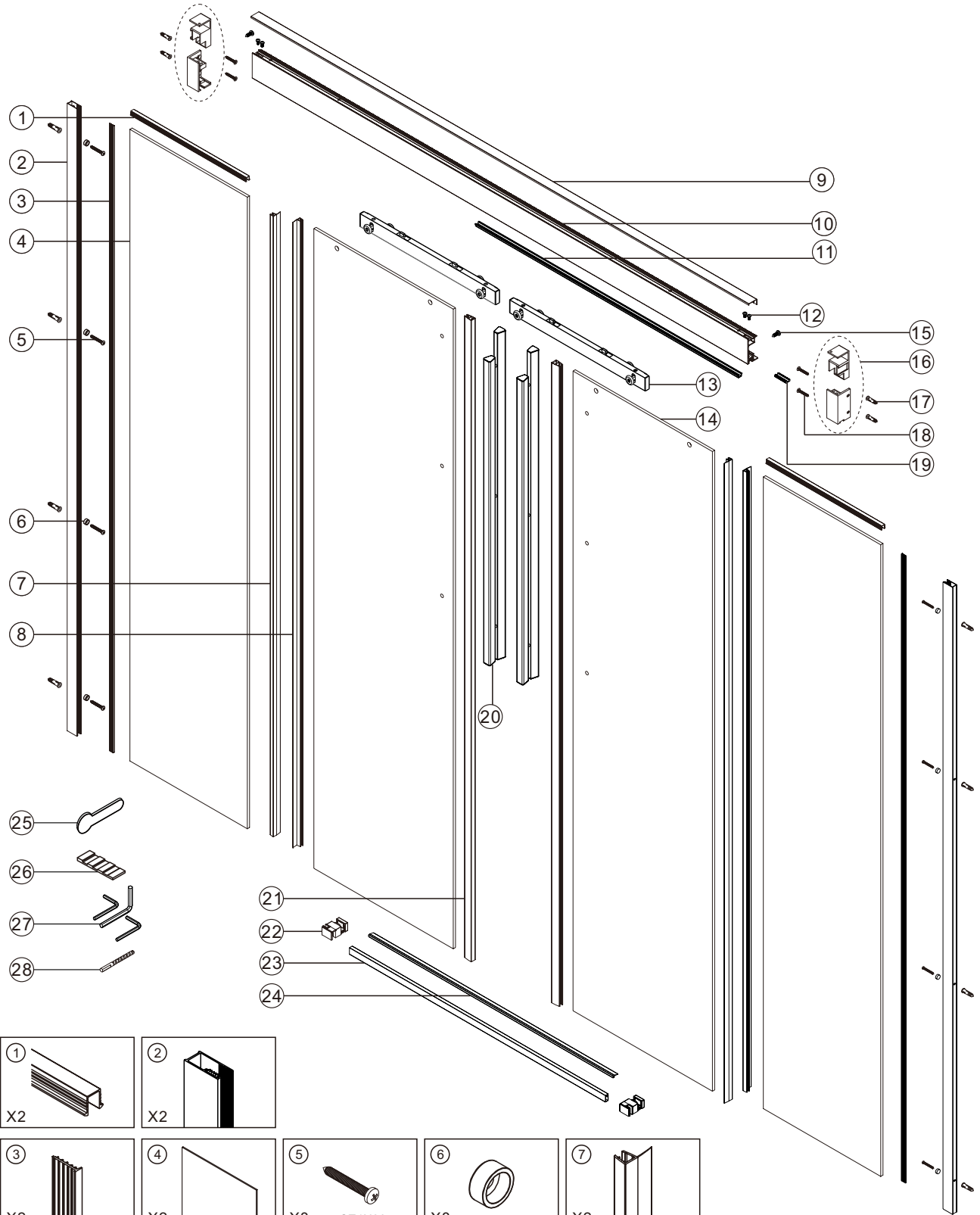

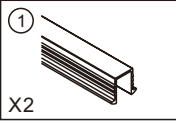
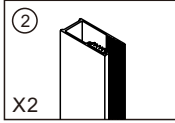
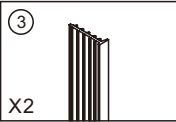
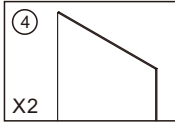
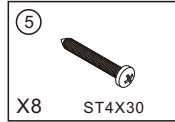
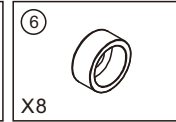
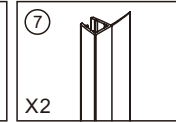
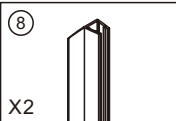
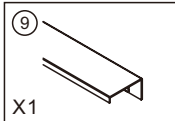
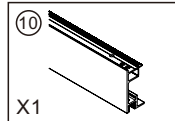
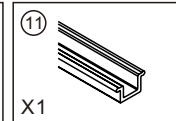
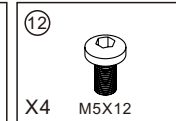
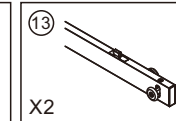
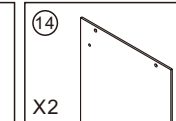
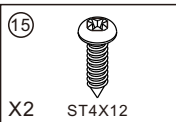
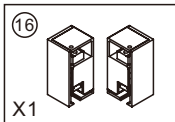
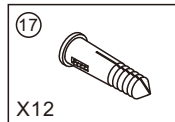
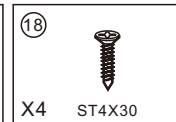
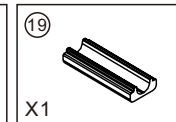
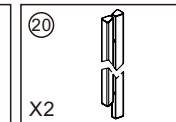
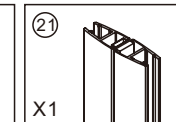
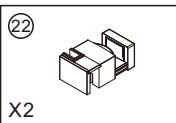
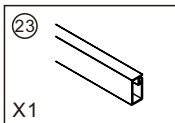
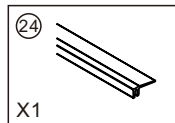
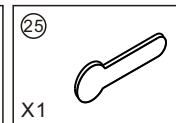
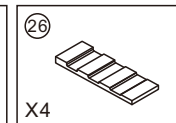
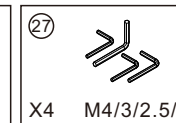
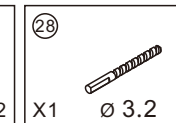
 X2	 X2											
 X2	 X2	 X8 ST4X30	 X8	 X2								
 X2	 X1	 X1	 X1	 X4 M5X12	 X2	 X2						
 X2 ST4X12	 X1	 X12	 X4 ST4X30	 X1	 X2	 X1						
 X2	 X1	 X1	 X1	 X4	 X4 M4/3/2.5/2	 X1 Ø 3.2						

PARTS LIST

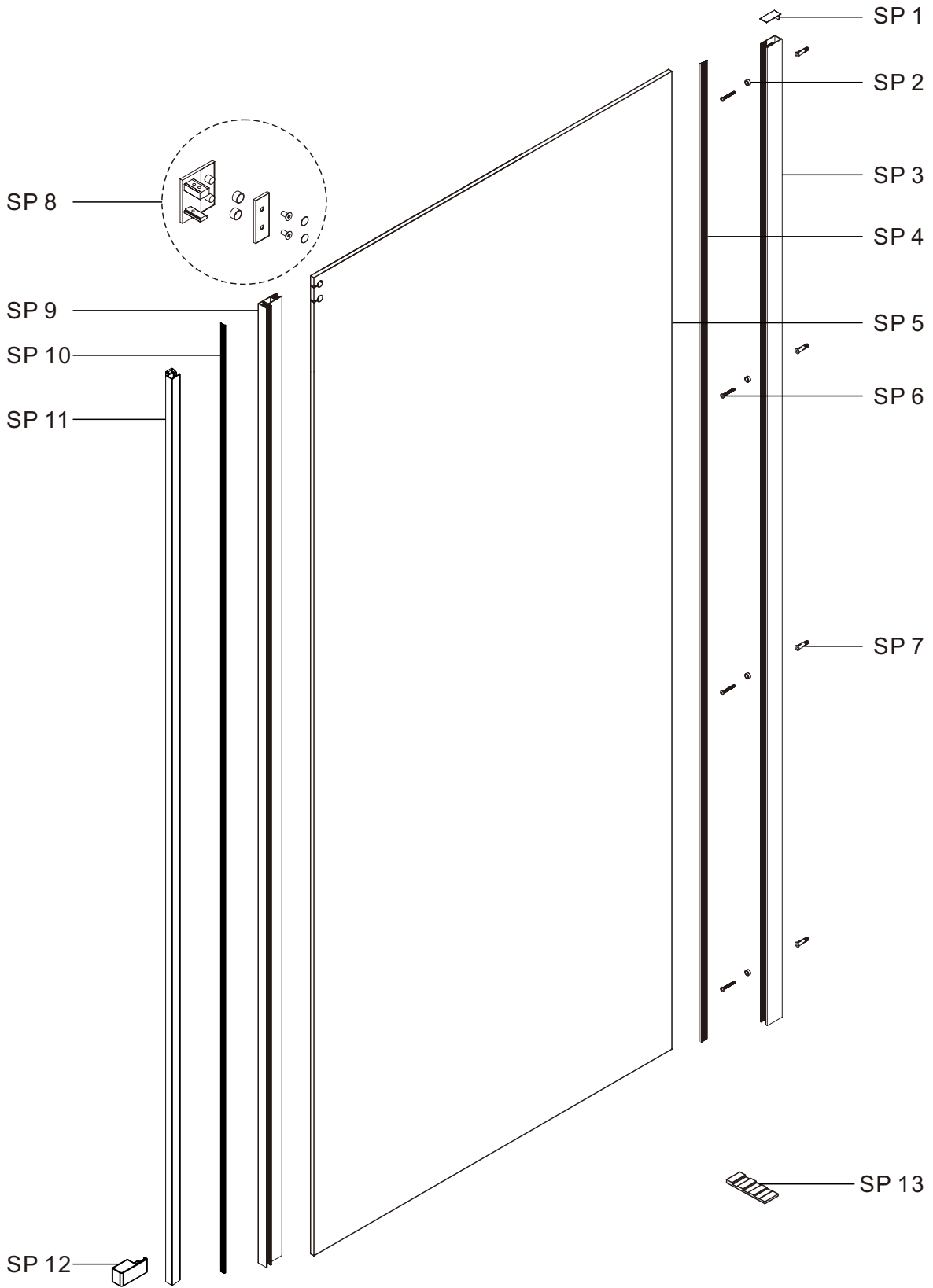

① X1 	② X1 	③ X1 	④ X1 	⑤ X1 	⑥ X4 ST4X30 	⑦ X4
⑧ X1 	⑨ X1 	⑩ X1 	⑪ X1 	⑫ X1 	⑬ X2 	

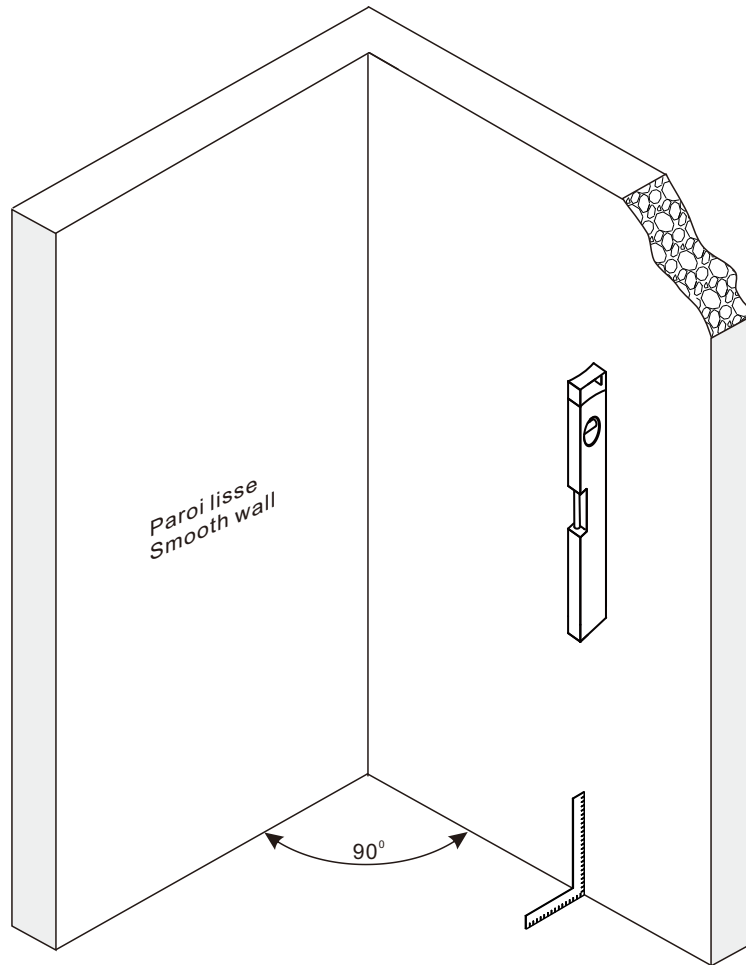

TOOLS AND MATERIALS REQUIRED

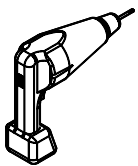

PERCEUSE
DRILL



VIS
SCREWS

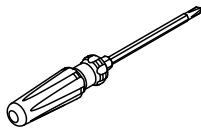

TOURNEVIS
SCREWDR

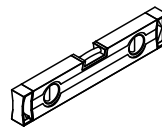

NIVEAU
LEVEL

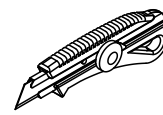

COUTEAU DE PRECISION
PRECISION KNIFE



SILICONE
SILICONE

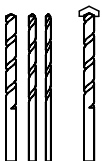

FORETS: 1/8", 3/16" ET 1/4"
*FORET À MAÇONNERIE
DRILL BITS: 1/8", 3/16" ET 1/4"
*MASONRY DRILL BIT

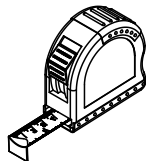

RUBAN À MESURER
MEASURING TAPE



ÉQUERRE
SET SQUARE

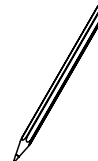

CRAYON
PENCIL

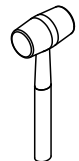

MAILLET
MALLET

CONTINUED

A 01

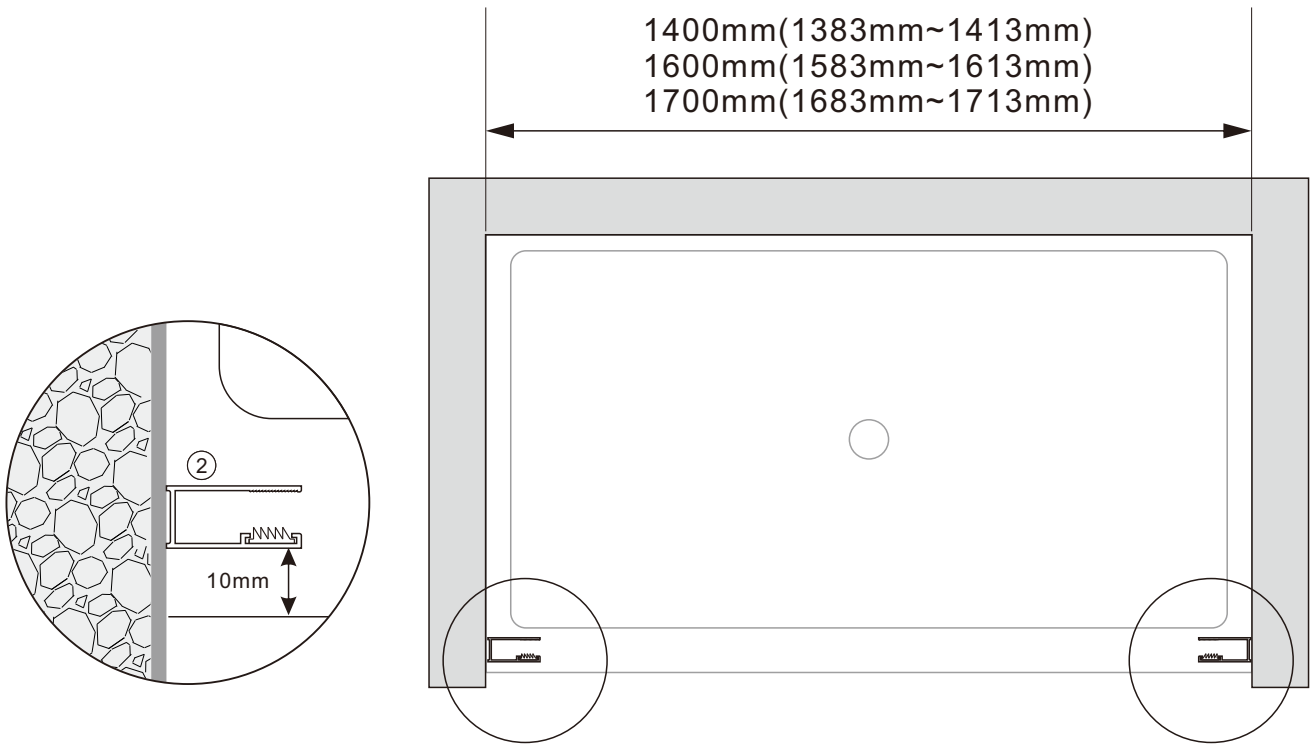

CONTINUED

A 02

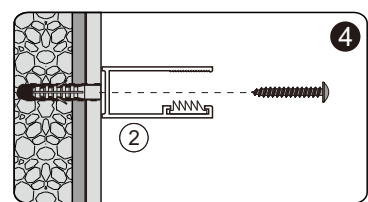
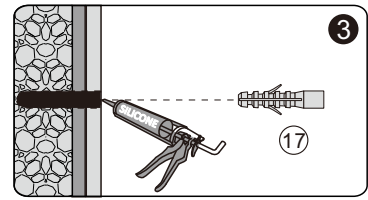
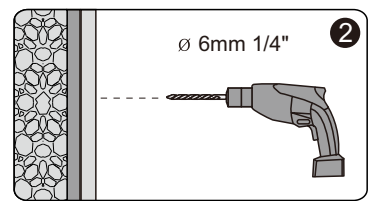
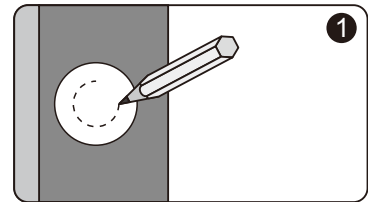
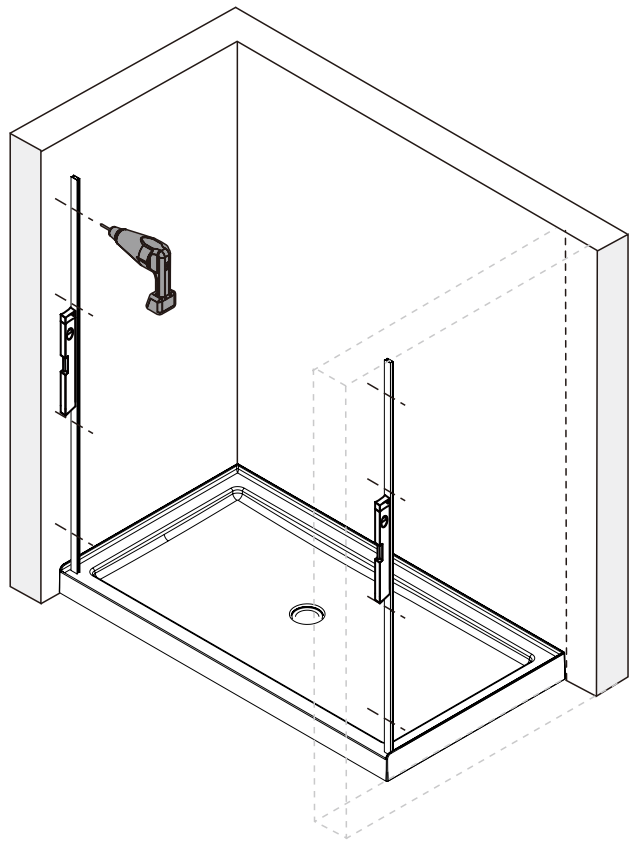

CONTINUED

A 03

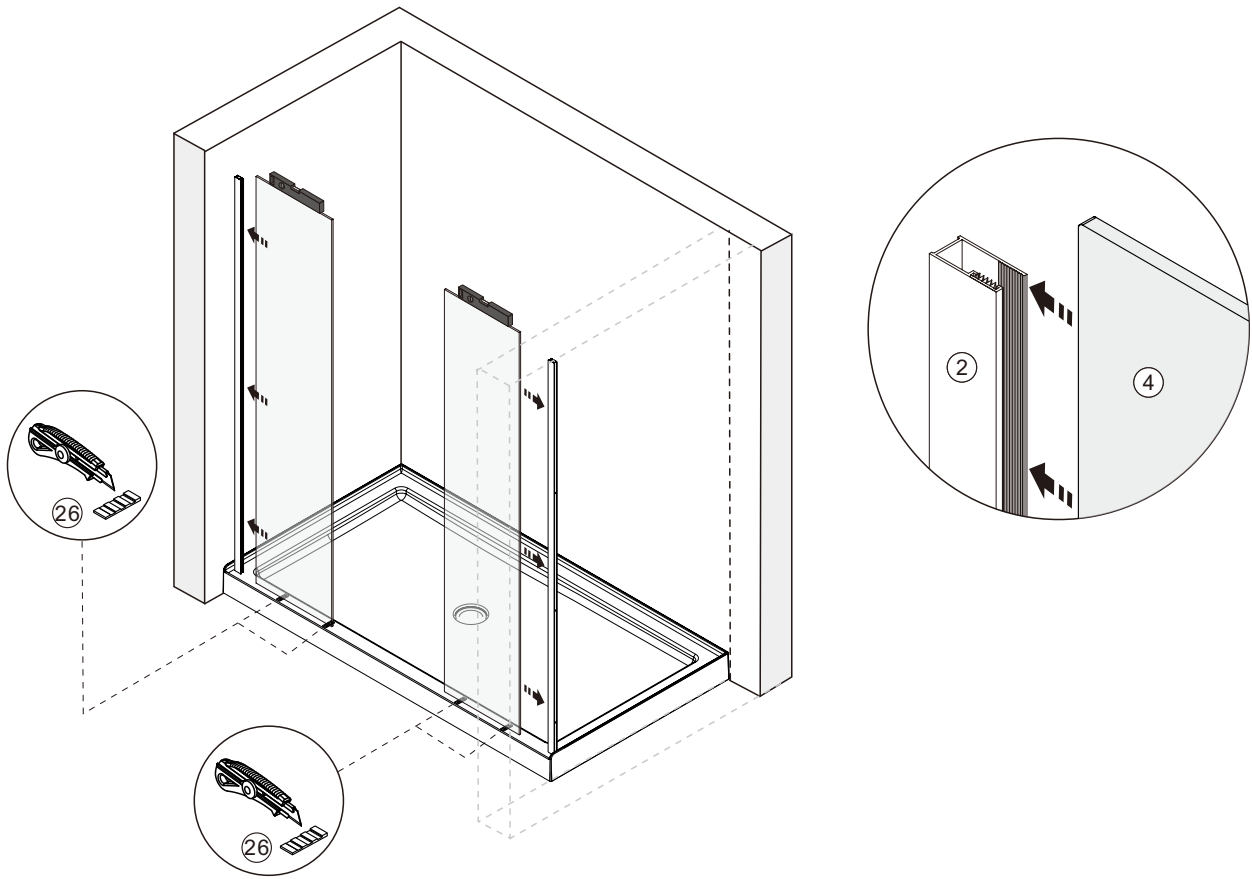

CONTINUED

A 04

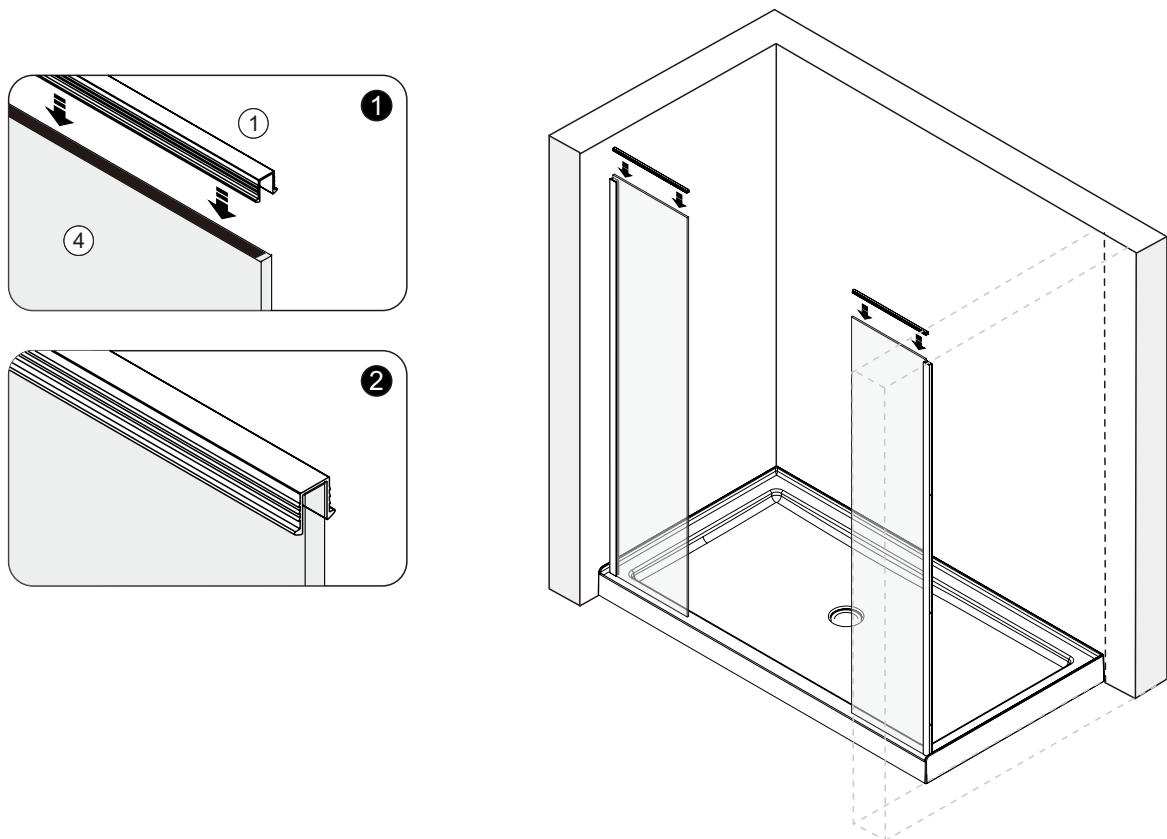

CONTINUED

A₀₅

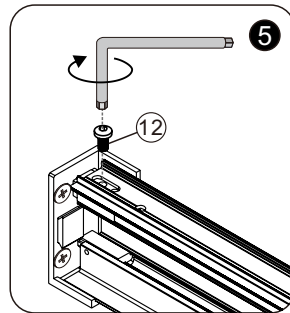
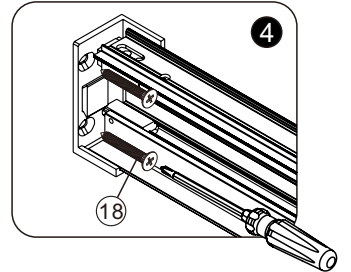
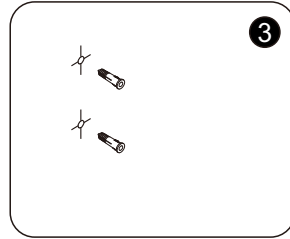
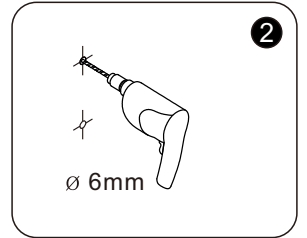
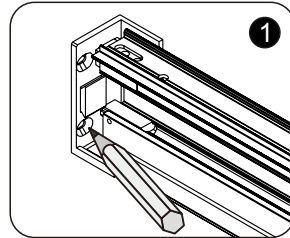
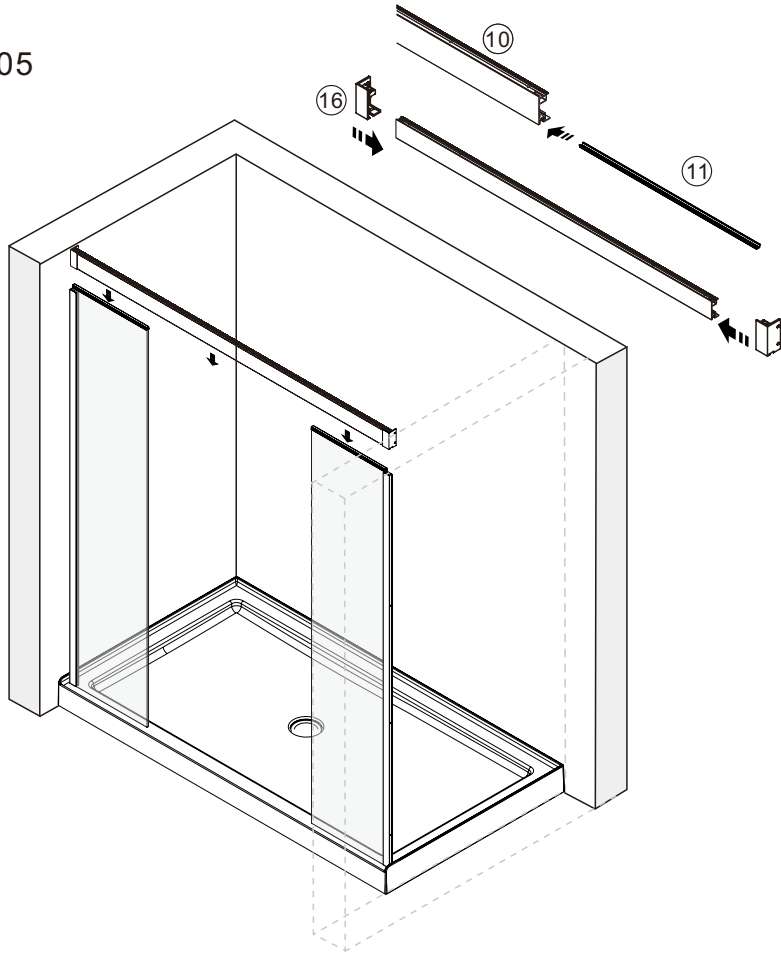

CONTINUED

A₀₆

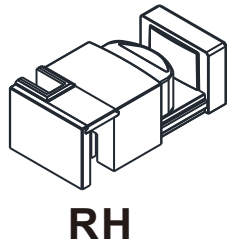

RH

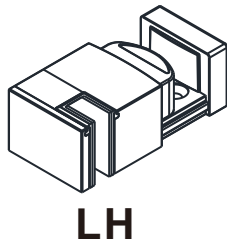

LH

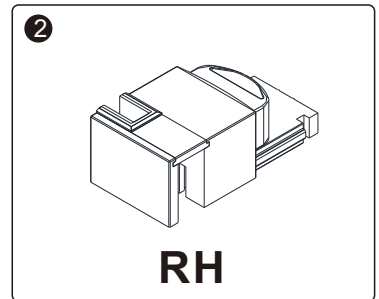
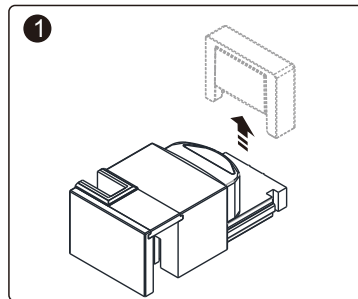
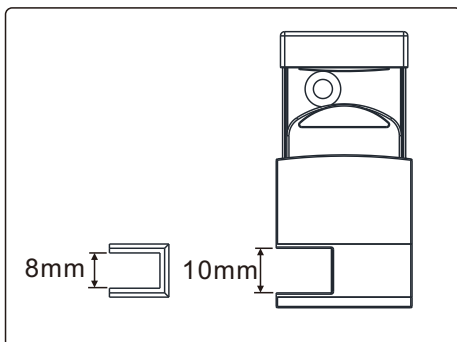

RH

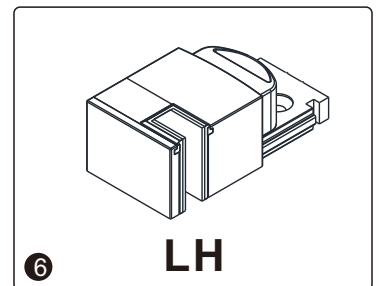
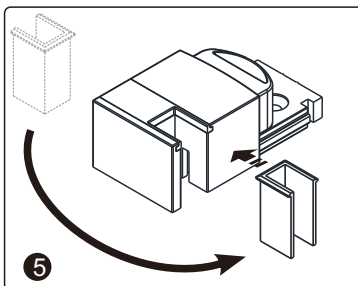
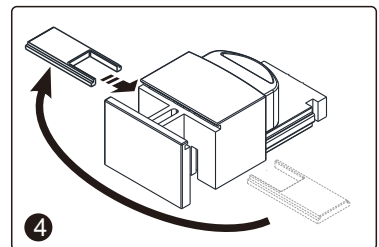
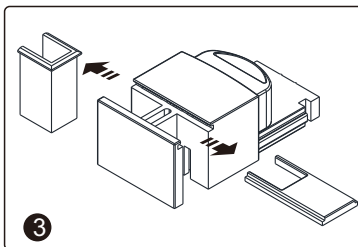

LH

CONTINUED

A 07

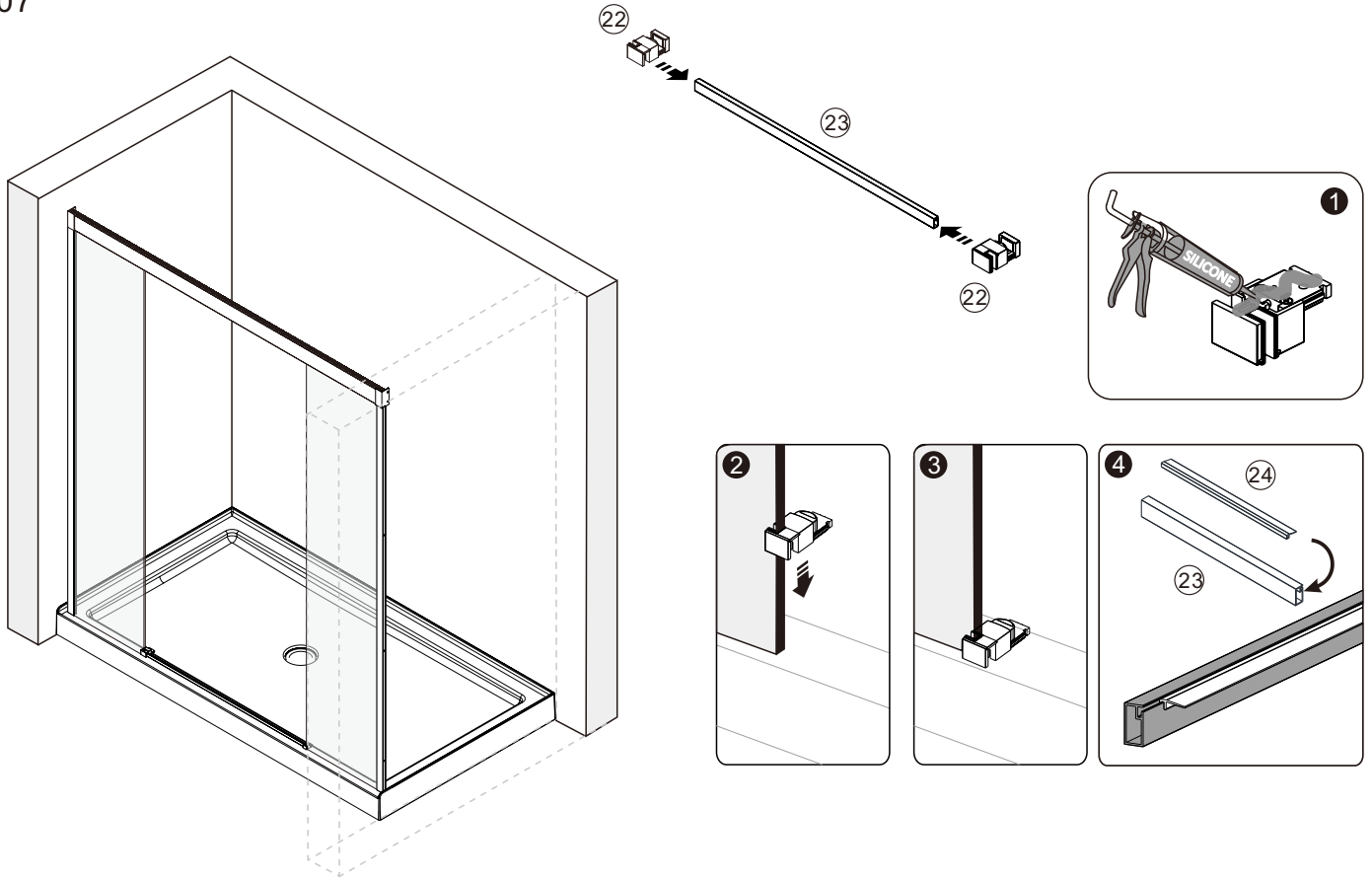

CONTINUED

A 08

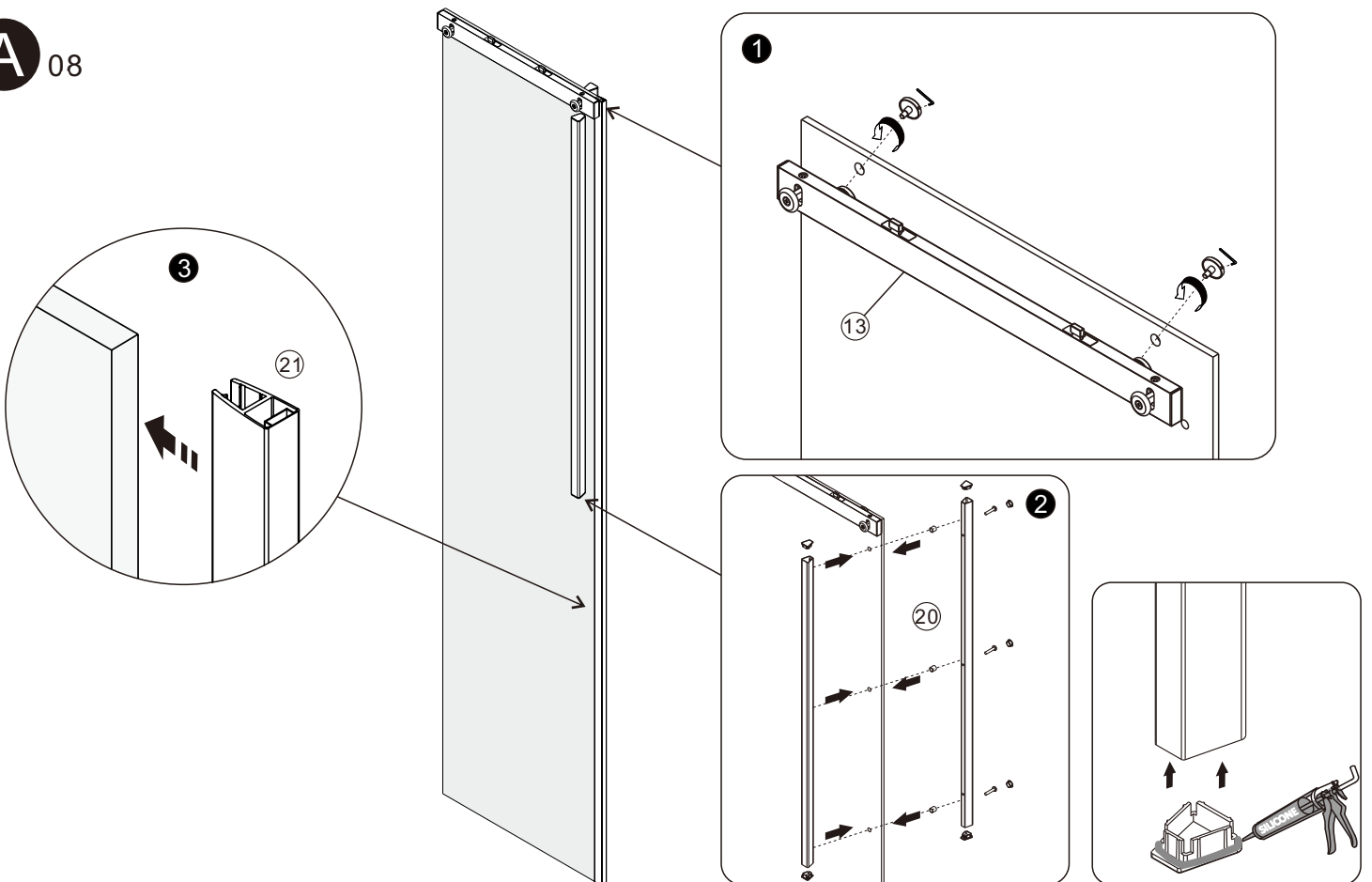

A 09

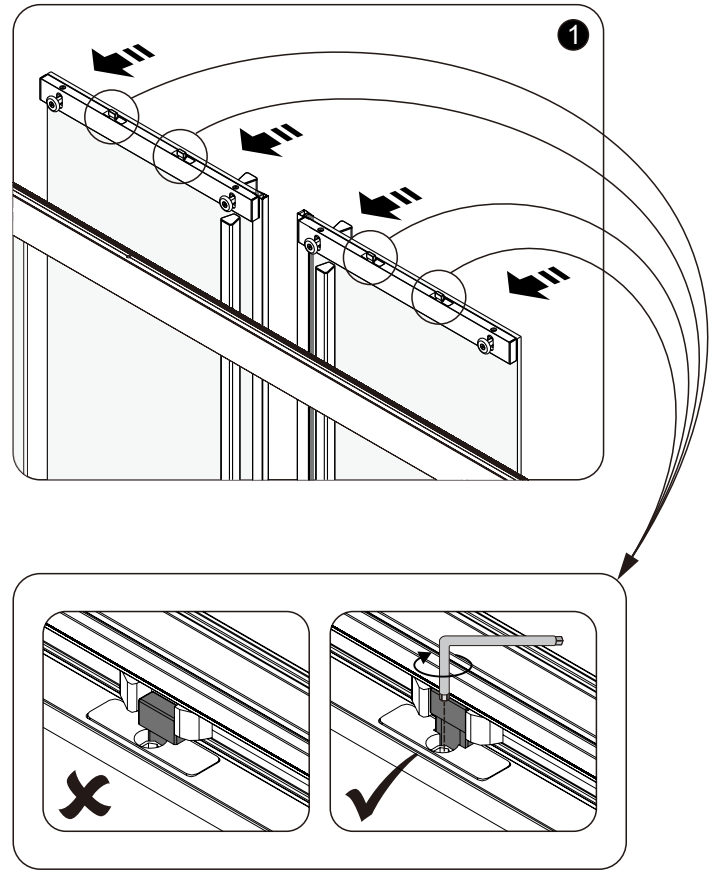
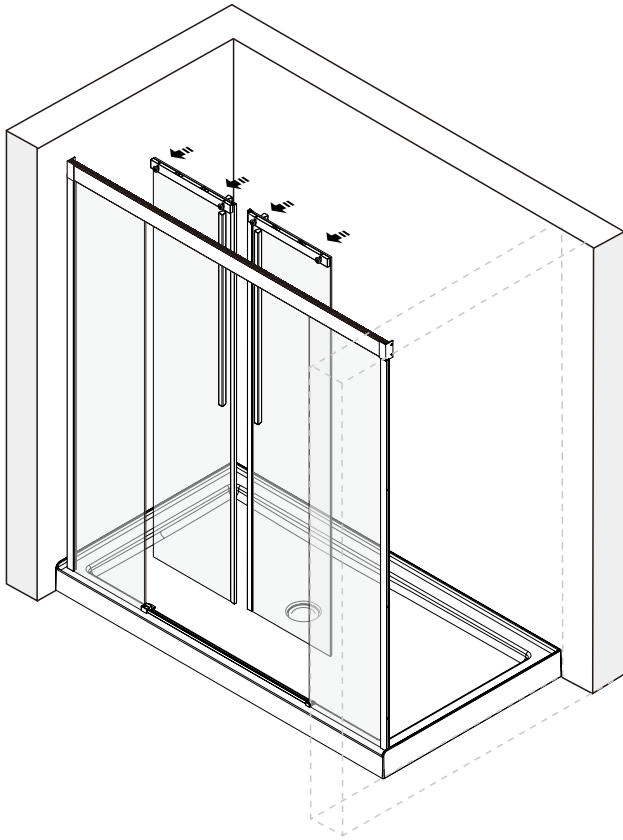

A 10

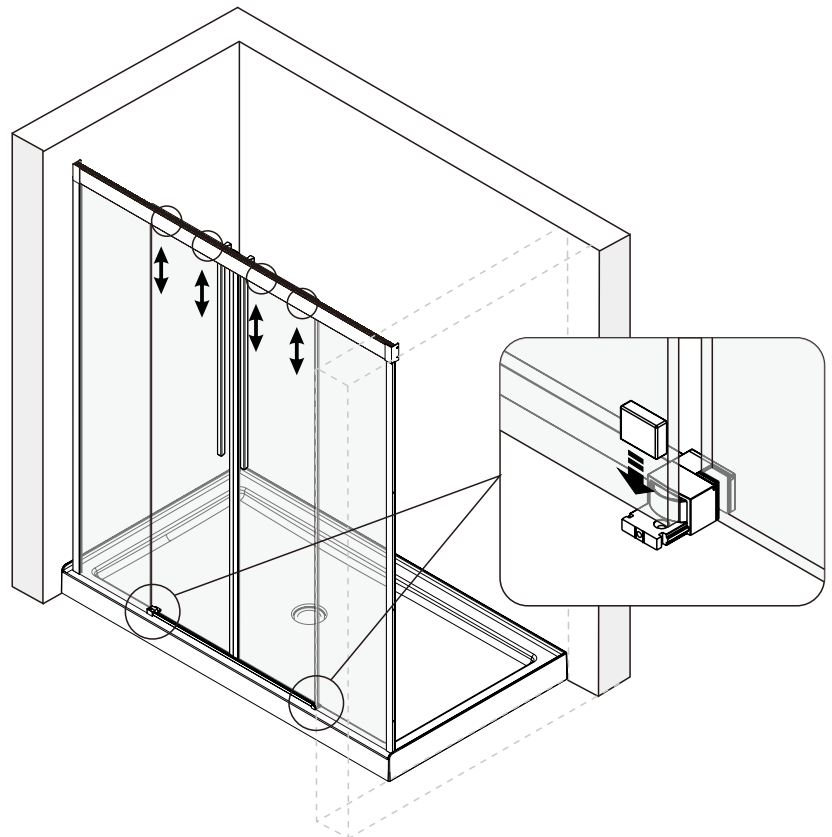
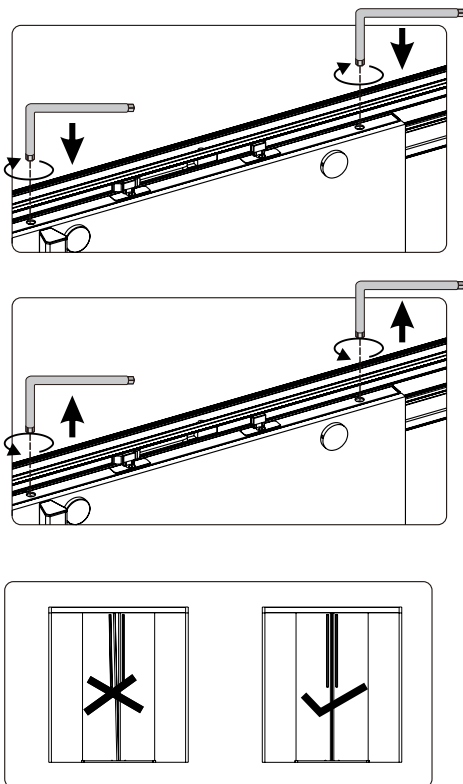

A 11

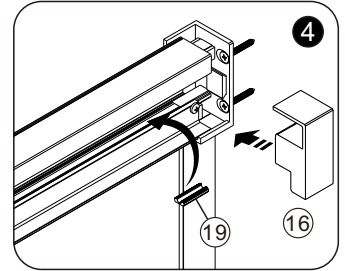
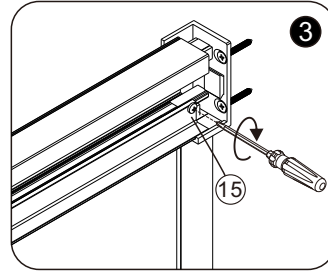
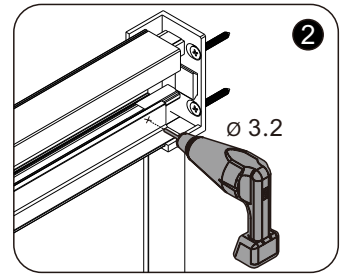
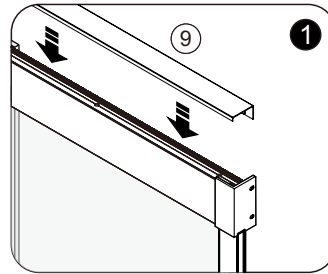
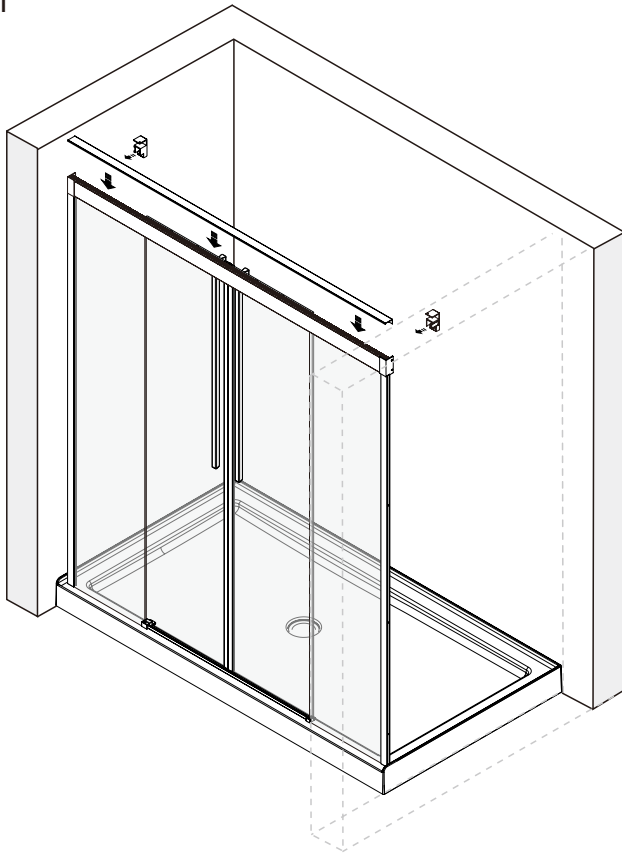

A 12

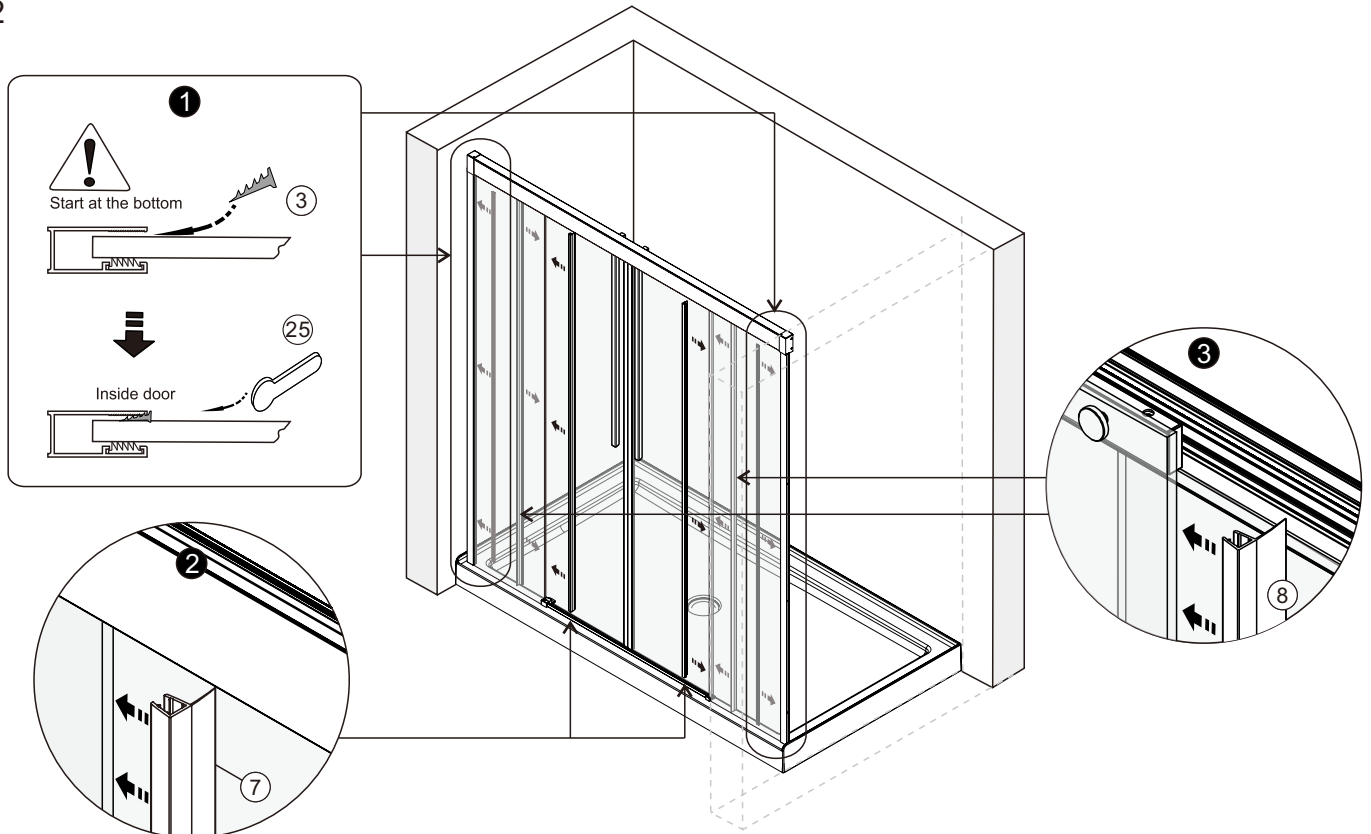

A 13

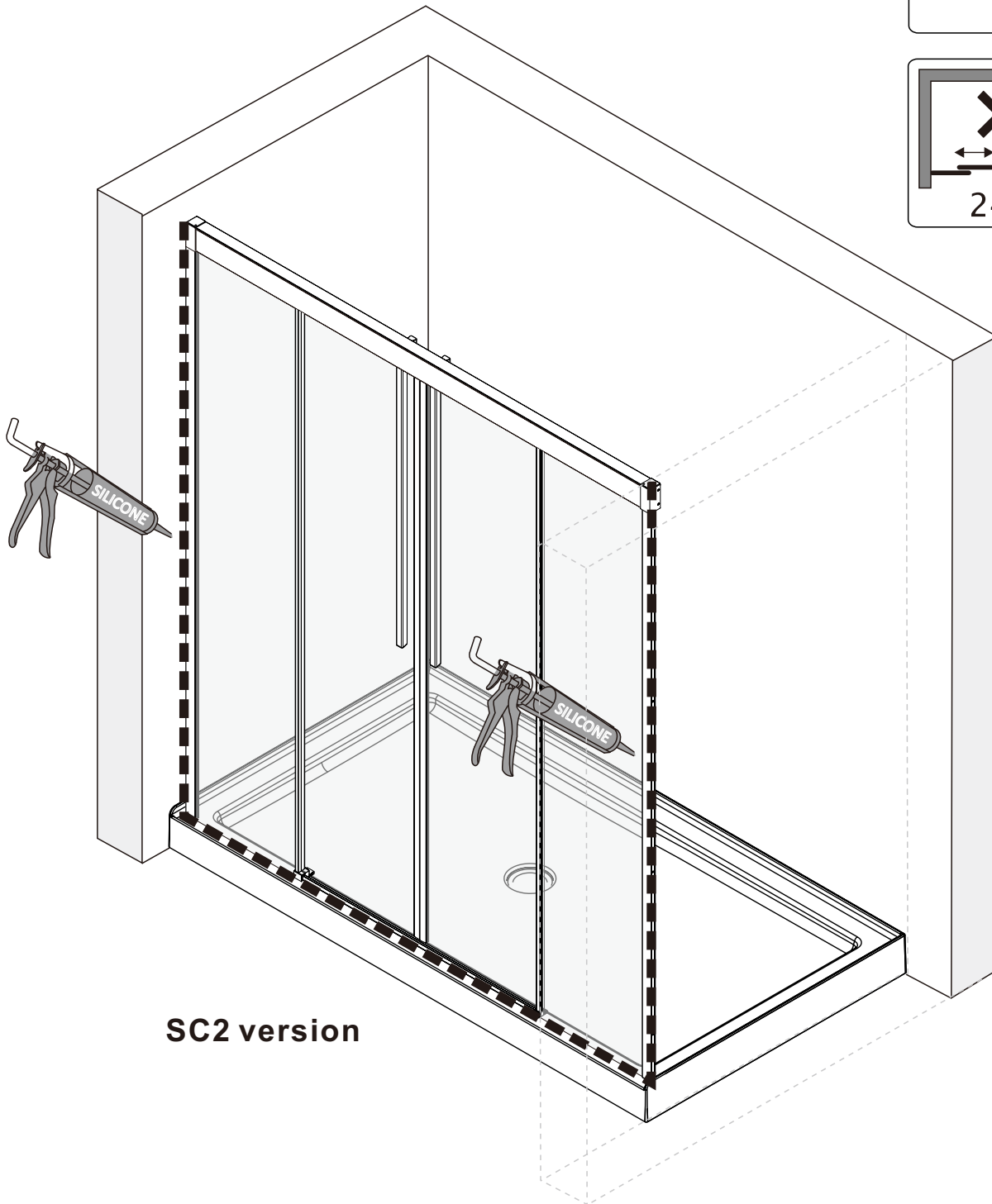
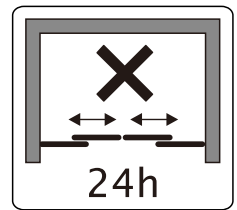
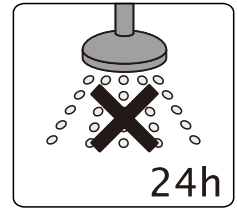

SC2 version

CONTINUED

B₀₁

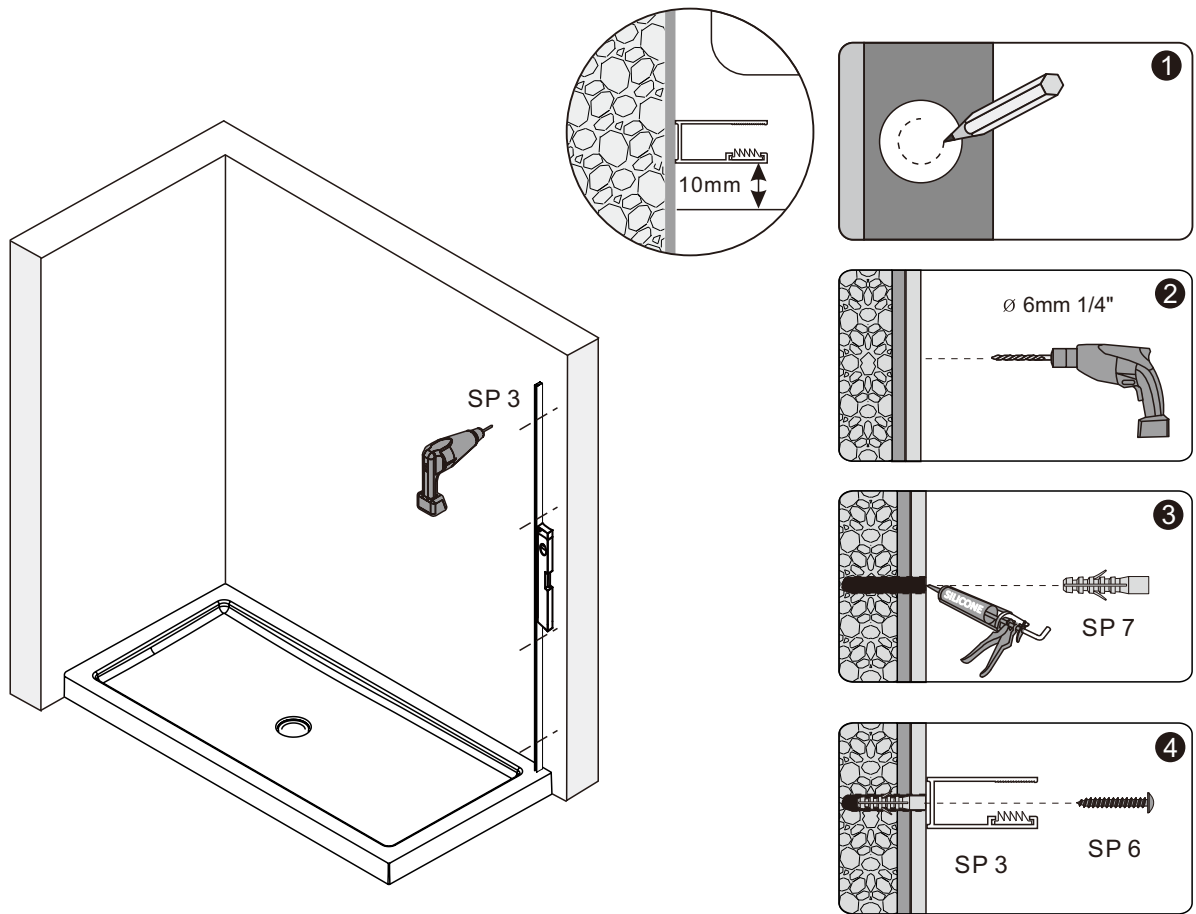

CONTINUED

B₀₂

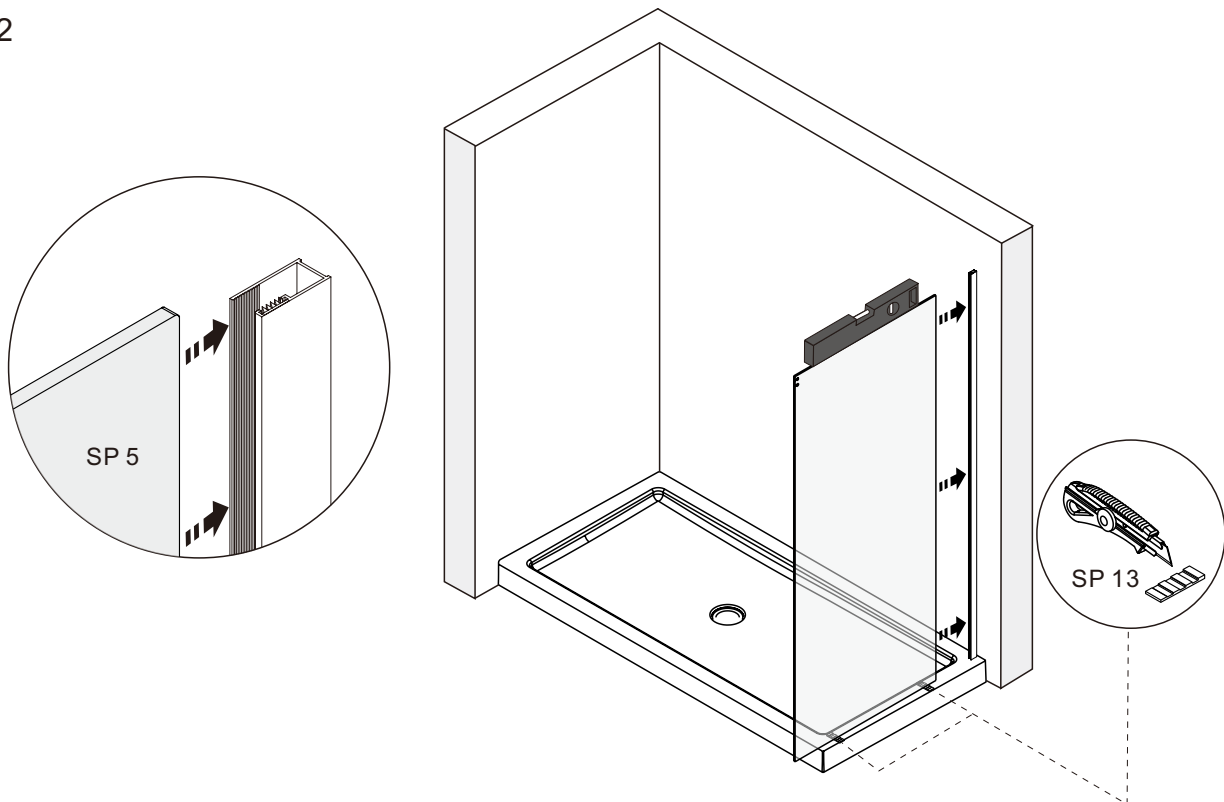

B 03

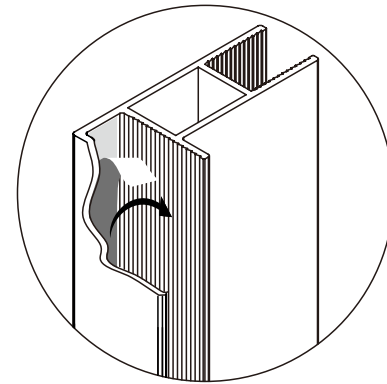
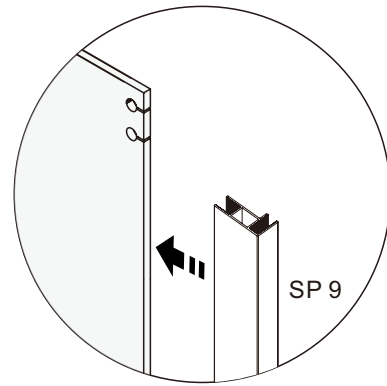
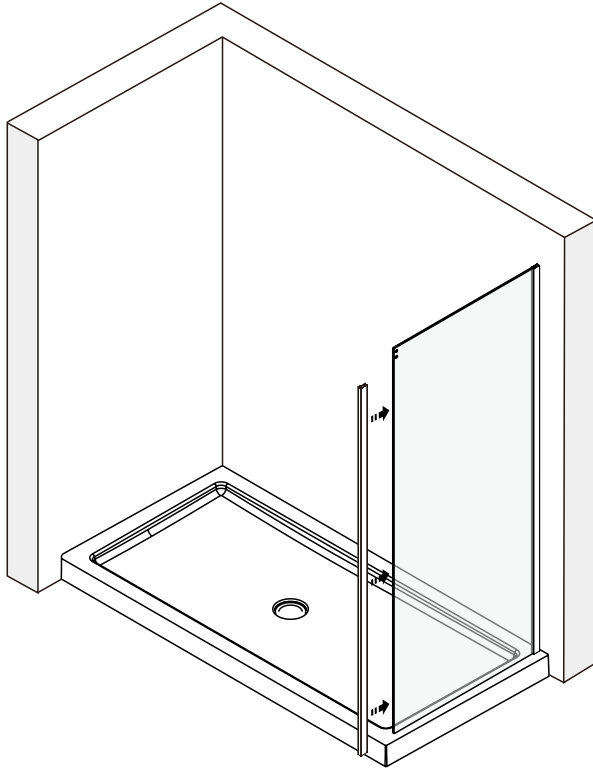

Split here the 3m tape

B 04

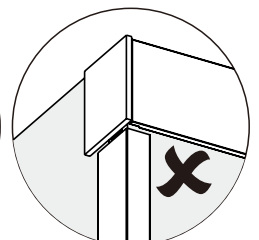
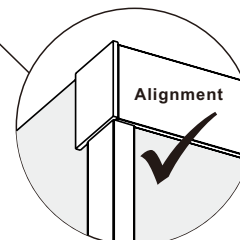
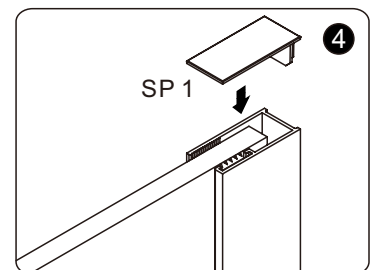
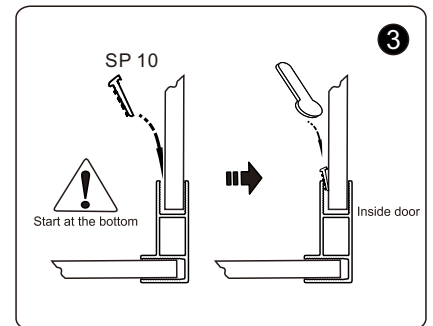
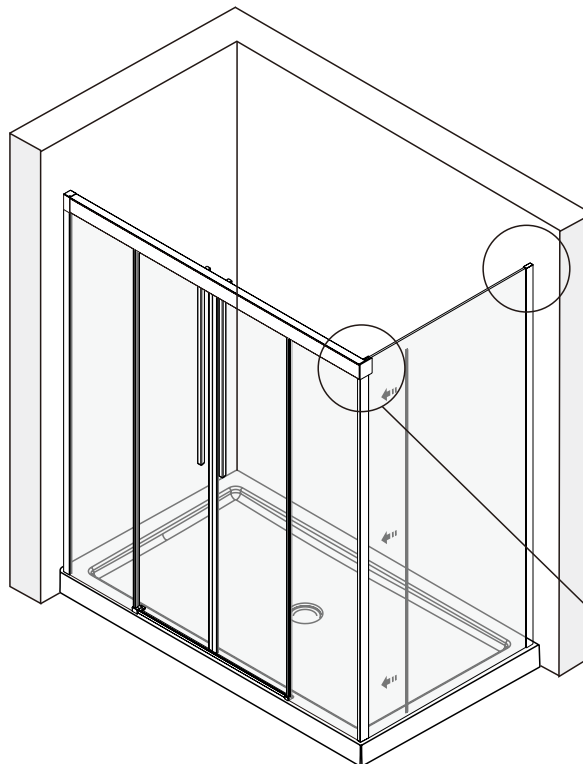
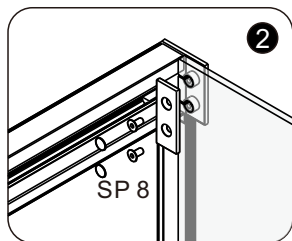
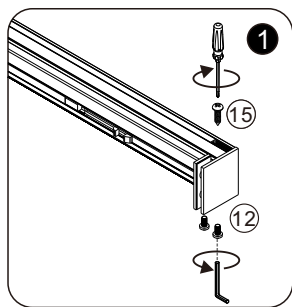

CONTINUED

B 05

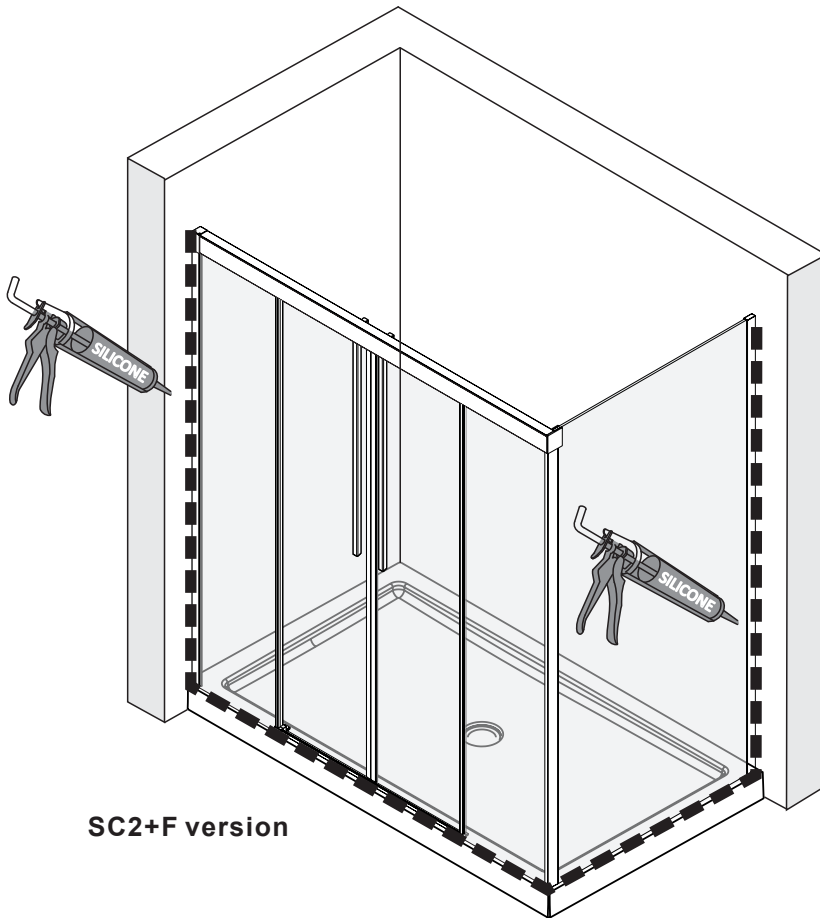

SC2+F version

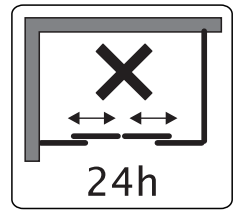
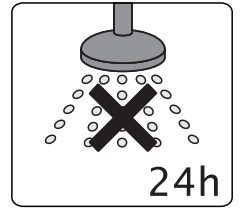

CONTINUED

C 01

SC2+F+F version

